



***OWNER'S MANUAL
TD80 Treadmill***

*Please carefully read this entire manual
before operating your new treadmill.*

ATTENTION: *Before returning your Sole product to any retailer, or if you require any assistance with assembly or technical support please call us first for assistance at 866-697-6531. Thank you for your Sole purchase.*

TABLE OF CONTENTS

<u>Product Registration</u>	2
<u>Important Safety Instructions</u>	3
<u>Important Electrical Instructions</u>	4
<u>Grounding Instructions</u>	4
<u>Important Operation Instructions</u>	5
<u>Assembly Instructions</u>	9
<u>Folding Instructions</u>	15
<u>Transport Instructions</u>	15
<u>Console Operation</u>	16
<u>Setting Stride Length for Step Count</u>	19
<u>General Maintenance</u>	20
<u>Service Checklist – Diagnosis guide</u>	23
<u>Manufacturer’s Limited Warranty</u>	25



WARNING: This product can expose you to chemicals including Toluene and Acrylamide which are known to the State of California to cause Cancer and birth defects or other reproductive harm. For more information, go to www.P65Warnings.ca.gov

Before returning your Sole product to any retailer, or if you require any assistance with assembly or technical support please call us first for assistance at 866-697-6531. Thank you for your Sole purchase.

SOLE

FITNESS

CONGRATULATIONS ON YOUR NEW TREADMILL AND WELCOME TO THE SOLE FAMILY!

Thank you for your purchase of this quality treadmill from **SOLE**. Your new treadmill has been manufactured by one of the leading fitness manufacturers in the world and is backed by one of the most comprehensive warranties available. **SOLE** will do all we can to make your ownership experience as pleasant as possible for many years to come.

If you have any questions about your new product contact **SOLE Fitness at 866-780-SOLE (7653)**. If you have a technical problem with your new treadmill contact **SOLE technical service at 866-MYSOLE1 (1-866-697-6531)**.

Please take a moment at this time to record below the name of the dealer, their telephone number, and the date of purchase for easy contact in the future. We appreciate your confidence in **SOLE** and we will always remember that you are the reason that we are in business. Please complete and mail your registration card today and enjoy your new treadmill.

Yours in Health,
SOLE Fitness

Name of Dealer _____

Telephone Number of Dealer _____

Purchase Date _____

PRODUCT REGISTRATION

RECORD YOUR SERIAL NUMBER

Please record the Serial Number of this fitness product in the space provided below.

Serial Number _____



REGISTER YOUR PURCHASE

The self-addressed product registration card must be completed in full and returned to **SOLE**. You can also go to www.soletreadmills.com under the support tab to register online.

IMPORTANT SAFETY INSTRUCTIONS

WARNING - Read all instructions before using this equipment.

DANGER - To reduce the risk of electric shock disconnect your SOLE treadmill from the electrical outlet prior to cleaning and/or service work.

WARNING - To reduce the risk of burns, fire, electric shock, or injury to persons, install the treadmill on a flat level surface with access to a 120-volt, 15-amp grounded outlet with only the treadmill plugged into the circuit.

DO NOT USE AN EXTENSION CORD UNLESS IT IS A 14AWG OR BETTER, WITH ONLY ONE OUTLET ON THE END: DO NOT ATTEMPT TO DISABLE THE GROUNDED PLUG BY USING IMPROPER ADAPTERS, OR IN ANYWAY MODIFY THE CORD SET.

A serious shock or fire hazard may result along with computer malfunctions. See Grounding Instructions if applicable.

- Do not operate treadmill on deeply padded, plush or shag carpet. Damage to both carpet and treadmill may result.
- Do not block the rear of the treadmill. Provide a minimum of 3 1/2 feet clearance between the rear of the treadmill and any fixed object.
- Keep children under the age of 13 away from the treadmill. There are obvious pinch points and other caution areas that can cause harm.
- Keep hands away from all moving parts.
- Never operate the treadmill if it has a damaged cord or plug. If the treadmill is not working properly, call your dealer.
- Keep the cord away from heated surfaces.
- Do not operate where aerosol spray products are being used or where oxygen is being administered. Sparks from the motor may ignite a highly gaseous environment.
- Never drop or insert any object into any openings.
- Do not use outdoors.
- To disconnect, turn all controls to the off position, remove tether cord, and then remove the plug from the outlet.
- Do not attempt to use your treadmill for any purpose other than for the purpose it is intended.
- Wear proper shoes. Quality athletic shoes are recommended to avoid leg fatigue.
- Please verify and make sure safety key functions properly before using the treadmill. Always wear the safety key clip while in use.
- For energy savings, always unplug the power cord when treadmill is not in use.
- This equipment is not intended for use by persons with reduced physical, sensory or mental capabilities, or lack of experience and knowledge, unless they have been given supervision or instruction concerning use of the equipment by a person responsible for their safety.

Remove tether cord after use to prevent unauthorized treadmill operation.

SAVE THESE INSTRUCTIONS - THINK SAFETY!

IMPORTANT ELECTRICAL INSTRUCTIONS

WARNING!

NEVER use a ground fault circuit interrupt (GFCI) wall outlet with this treadmill. As with any appliance with a large motor, the GFCI will trip often. Route the power cord away from any moving part of the treadmill including the elevation mechanism and transport wheels.

NEVER remove any cover without first disconnecting AC power.

If voltage varies by ten percent (10%) or more, the performance of your treadmill may be affected. Such conditions are not covered under your warranty. If you suspect the voltage is low, contact your local power company or a licensed electrician for proper testing.

NEVER expose this treadmill to rain or moisture. This product is NOT designed for use outdoors, near a pool or spa, or in any other high humidity environment. Maximum operating temperature specification is 40 degrees C, and humidity is 95% non-condensing (no water drops forming on surfaces).

Circuit Breakers: Some circuit breakers used in homes are not rated for high inrush currents, (ARC fault breakers are one example) that can occur when a treadmill is first turned on or even during use. If your treadmill is tripping the circuit breaker (even though it is the proper current rating) but the circuit breaker on the treadmill itself does not trip, you will need to replace the home breaker with a high inrush type. This is not a warranty defect. This is a condition we as a manufacture have no ability to control. This part is available through most electrical supply stores. Examples: Grainger part # 1D237, or available online at www.squared.com part # QO120HM.

GROUNDING INSTRUCTIONS

This product must be grounded. If the treadmill should malfunction or breakdown, grounding provides a path of least resistance for electric current, reducing the risk of electric shock. This product is equipped with a cord having an equipment-grounding plug. The plug must be plugged into an appropriate outlet that is properly installed and grounded in accordance with all local codes and ordinances.

DANGER - Improper connection of the equipment-grounding conductor can result in a risk of electric shock. Check with a qualified electrician or serviceman if you are in doubt as to whether the product is properly grounded. Do not modify the plug provided with the product if it will not fit the outlet; have a proper outlet installed by qualified electrician.

This product is for use on a nominal 120 volt/15 amp circuit, and has a grounding plug that looks like the plug illustrated below. A temporary adapter that looks like the adapter illustrated below may be used to connect this plug to a 2-pole receptacle as shown below if a properly grounded outlet is not available. The temporary adapter should be used only until a properly grounded outlet, (shown below) can be installed by a qualified electrician. The green colored rigid ear lug, or the like, extending from the adapter, must be connected to a permanent ground such as a properly grounded outlet box cover. Whenever the adapter is used, it must be held in place by a metal screw.

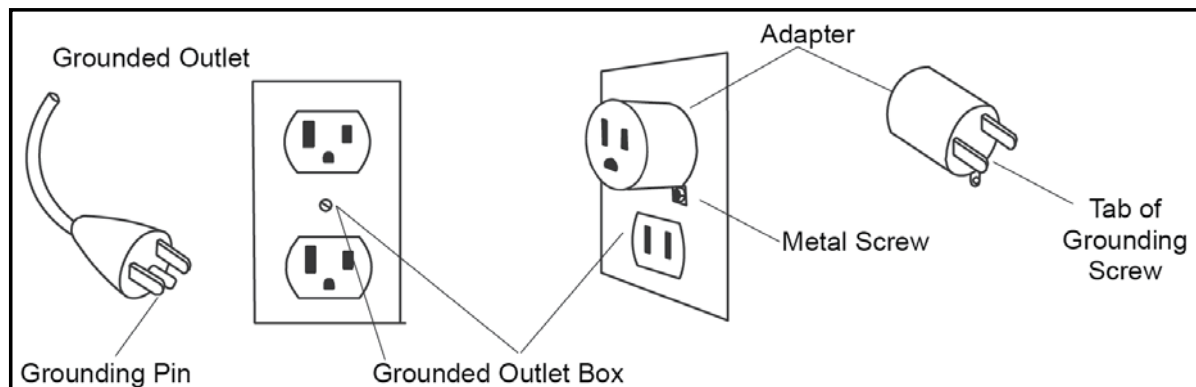

IMPORTANT OPERATION INSTRUCTIONS

- **NEVER** operate this treadmill without reading and completely understanding the results of any operational change you request from the computer.
- Understand that changes in speed do not occur immediately. Set your desired speed on the computer console and release the adjustment key. The computer will obey the command gradually.
- **NEVER** use your treadmill during an electrical storm. Surges may occur in your power supply that could damage treadmill components. Unplug the treadmill during an electrical storm as a precaution.
- Use caution while participating in other activities while walking on your treadmill. Distractions may cause you to lose balance or stray from walking in the center of the belt; which may result in serious injury.
- **NEVER** mount or dismount the treadmill while the belt is moving. Treadmills start at a very low speed and it is unnecessary to straddle the belt during start up. Simply standing on the belt during slow acceleration is proper after you have learned to operate the unit.
- Do not use excessive pressure on console control keys. They are precision set to function properly with little finger pressure. If you feel the buttons are not functioning properly with normal pressure contact your **SOLE** dealer.

SAFETY TETHER CORD

A safety tether cord is provided with this unit. It is a simple magnetic design that should be used at all times. It is for your safety should you fall or move too far back on the tread-belt. Pulling this safety tether cord will stop tread-belt movement.

To Use:

1. Place the magnet into position on the red portion of the console control head between the Start and Stop keys. Your treadmill will not start and operate without this. Removing the magnet also secures the treadmill from unauthorized use.
2. Fasten the plastic clip onto your clothing securely to assure good holding power.
Note: The magnet has strong enough power to minimize accidental, unexpected stopping. The clip should be attached securely to make certain it does not come off. Be familiar with its function and limitations. The treadmill will stop, depending on speed, with a one to two step coast anytime the magnet is pulled off the console. Use the red Stop / Pause switch in normal operation.

PREVENTATIVE MAINTENANCE CHART

Vacuum Under Motor Cover&Check Wiring (Every Other Month)	Clean&Inspect Deck for Lubrication (Every Other Month)	Lubricate Deck (Every 90 hours of use or sooner if dry)	Inspect Belt Tracking(Monthly) Adjust if necessary	Date

TREADMILL DESK ASSEMBLY INSTRUCTIONS

!!ATTENTION: IMPORTANT UNPACKING INSTRUCTIONS.

PLEASE READ BEFORE UNPACKING YOUR TREADMILL DESK!!

Serious injury could occur if this treadmill is not unpacked properly. There is a Velcro strap installed around the treadmill base that prevents the treadmill from unfolding accidentally during shipping. If this strap is not removed properly the treadmill could spring open unexpectedly and cause injury if someone is standing near the treadmill when the strap is removed.

To ensure your personal safety during removal of the shipping strap please make sure the treadmill is positioned flat on the ground, in the orientation it would be in if you were using the treadmill. Do not turn the treadmill up on its side while removing the shipping strap. This could cause the treadmill's folding mechanism to spring open. If the end of the Velcro strap (that you need to grab to remove it) happens to be under the treadmill deck, reach under the deck to grab it, but do not tilt the treadmill up to gain access to the strap end.

Cut the banding straps with a short box cutter (razor knife); separate the carton from the one underneath it by prying up on the staples (if applicable). Pull the carton over the treadmill parts and locate the hardware pack. The hardware pack is separated into five sections; one section containing tools and four sections labeled steps 1-4 which contain the hardware needed for assembly of each step. The assembly steps below are numbered one through four and correspond to the hardware in the numbered sections of the hardware pack. Remove only the hardware for the step you are currently assembling to avoid confusion and mix ups.

Then remove the treadmill from the carton and lay it on a level surface.

ASSEMBLY TOOLS

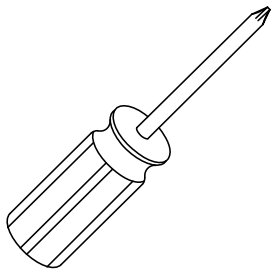

#139. Phillips Head Screw Driver

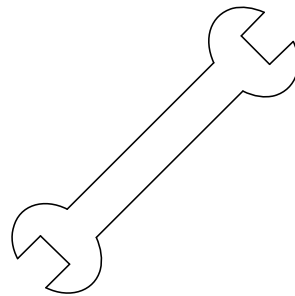

#140. 13/14mm Wrench

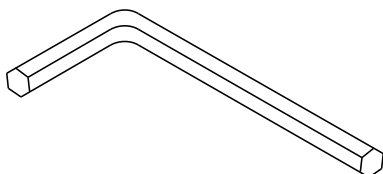

#141. M6 Allen Wrench

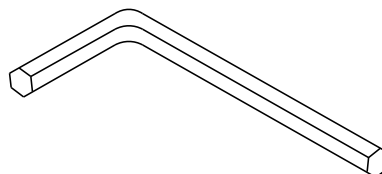

#142. M5 Allen Wrench

TD80 ASSEMBLY PACK CHECKLIST

1 HARDWARE STEP 1

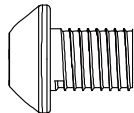

#135. 3/8" × 1/2" Button
Head Socket Bolt
(16 pcs)

2 HARDWARE STEP 2

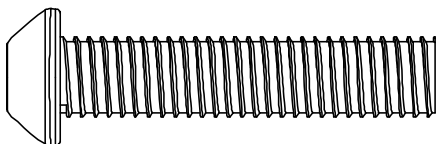

#136. 3/8" × 1-3/4"
Button Head Socket
Bolt (2 pcs)



#137. 3/8" × 7T
Nyloc Nut
(2 pcs)

3 HARDWARE STEP 3

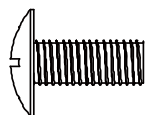

#112. M5 × 12mm
Phillips Head Screw
(4 pcs)

4 HARDWARE STEP 4

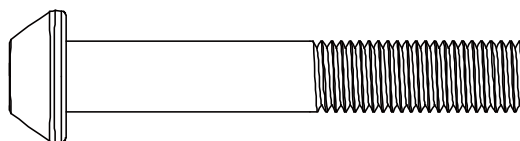

#70. 5/16" × 2"
Button Head Socket Bolt
(4 pcs)



#79. 5/16" × 7T
Nyloc Nut (4 pcs)

TD80 ASSEMBLY INSTRUCTIONS

1 HARDWARE STEP 1

HARDWARE STEP 1

#135. 3/8" × 1/2" Button Head Socket Bolt (16 pcs)

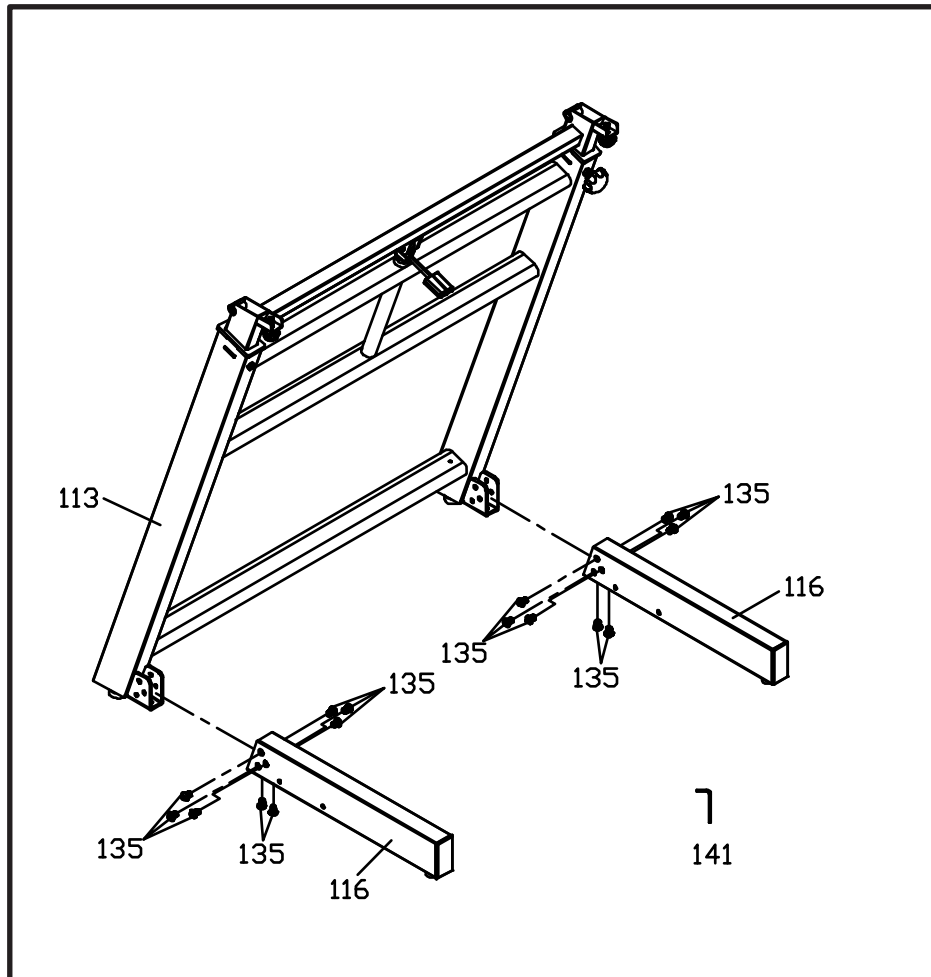

1. Connect the Fixed Upright Assembly (113) with the Frame Base Tube (L,R) (116) and use L Allen Wrench (141) to tighten 16pcs of 3/8" × UNC16 × 1/2" Button Head Socket Bolts (135).

2 HARDWARE STEP 2

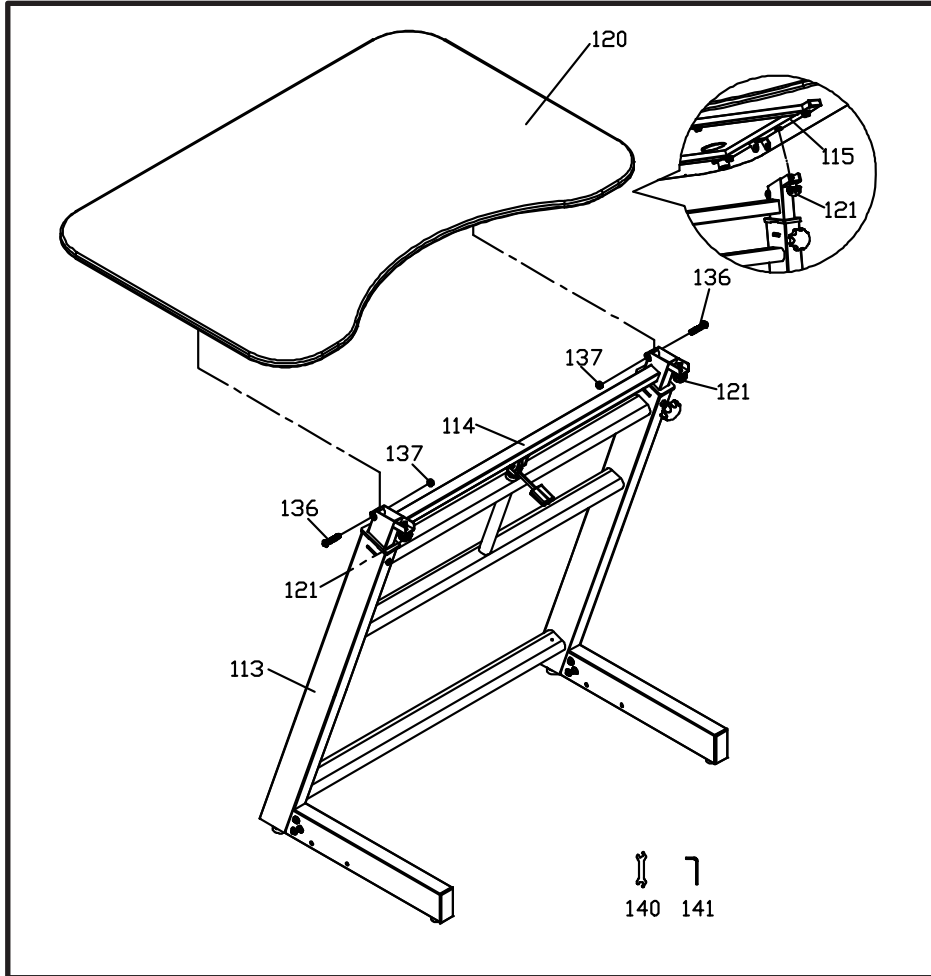

HARDWARE STEP 2

- #136. 3/8" × 1-3/4" Button Head Socket Bolt (2 pcs)
- #137. 3/8" × 7T Nyloc Nut (2 pcs)

1. Lay the Desk Board (120) on the Sliding Upright Assembly (114). Use two Nuts (121) to secure with Desk Board Stand (115). Secure the Desk Board Stand (115) onto the Sliding Upright Assembly (114) by using the open end of the wrench (140) and the Allen wrench (141) to tighten 2pcs of 3/8" × UNC16 × 1-3/4" Button Head Socket Bolts (136) and 2pcs of 3/8" × UNC16 × 7T_Nyloc Nuts (137).

3 HARDWARE STEP 3

HARDWARE STEP 3

#112. M5 × 12mm Phillips Head Screw (4 pcs)

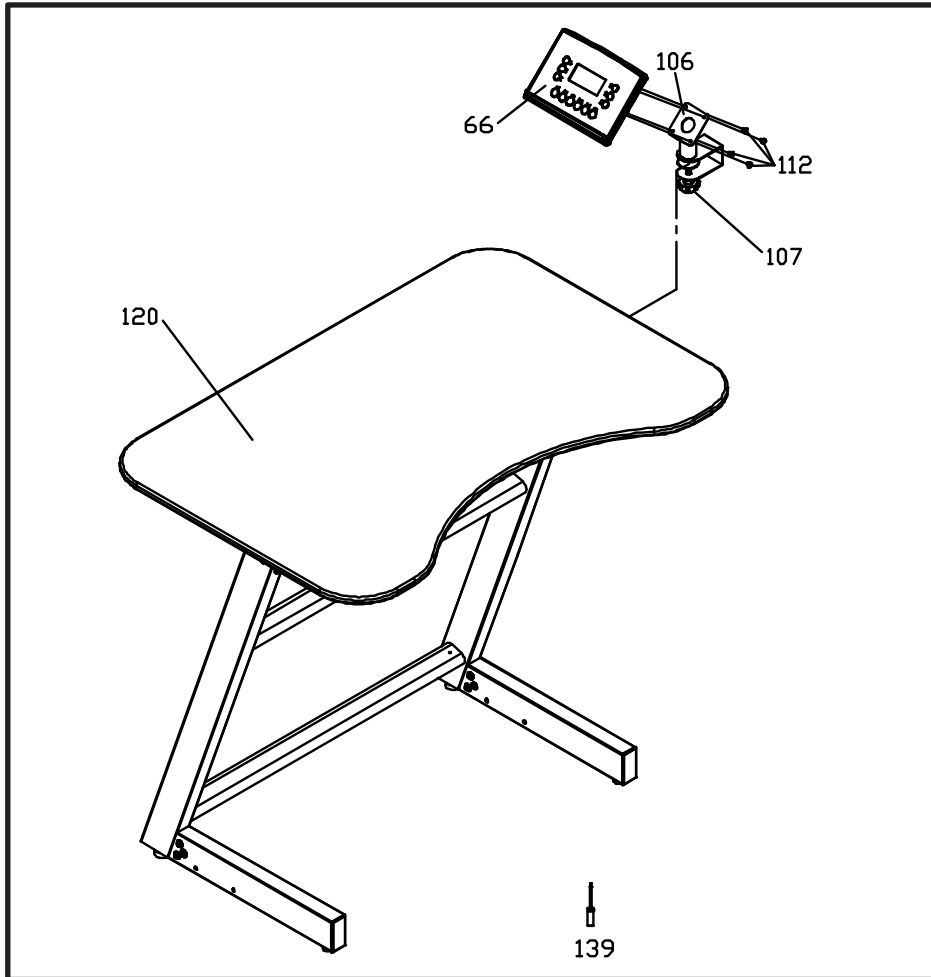

1. Slide the Computer Cable Upper (46) into the console Bracket assembly (106) to connect to the Console assembly (66). Use the Phillips Head Screwdriver (139) to tighten 4pcs of M5 × P0.8 × 12L_Phillips Head Screw (112) to secure the Console assembly (66) with the Console Bracket Assembly (106).
2. Locate the Console Bracket Assembly (106) on the right side of the Desk Board (120), to secure Console Bracket Assembly with the Tension Knob (107).

4 HARDWARE STEP 4

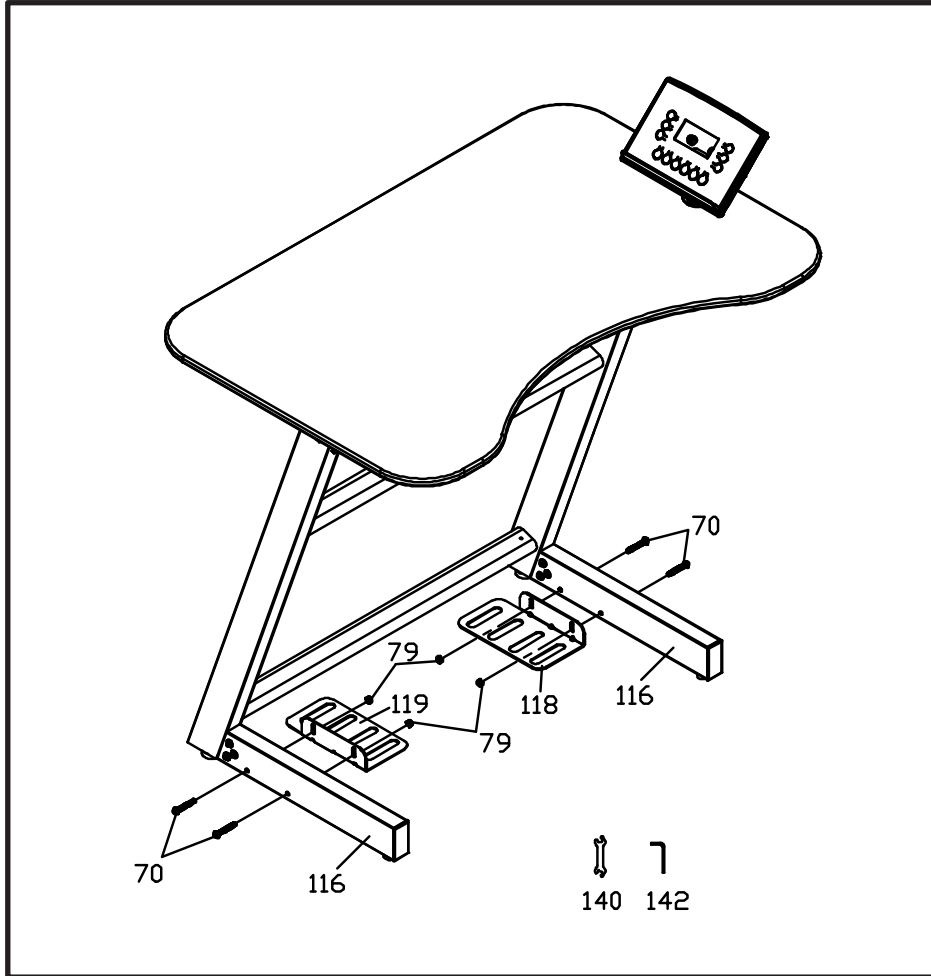

HARDWARE STEP 4

- #70. 5/16" × 2" Button Head Socket Bolt (4 pcs)
- #79. 5/16" × 7T Nyloc Nut (4 pcs)

1. Use the Allen wrench (142) and the Wrench (140) to tighten 4pcs of 5/16" × UNC18 × 2" Button Head Socket Bolts (70), together with 4pcs of 5/16" × UNC18 × 7T(mm) Nyloc Nuts (79) to secure the two Limit Brackets (R.L.) (118,119) through both Frame Base Tubes (116).

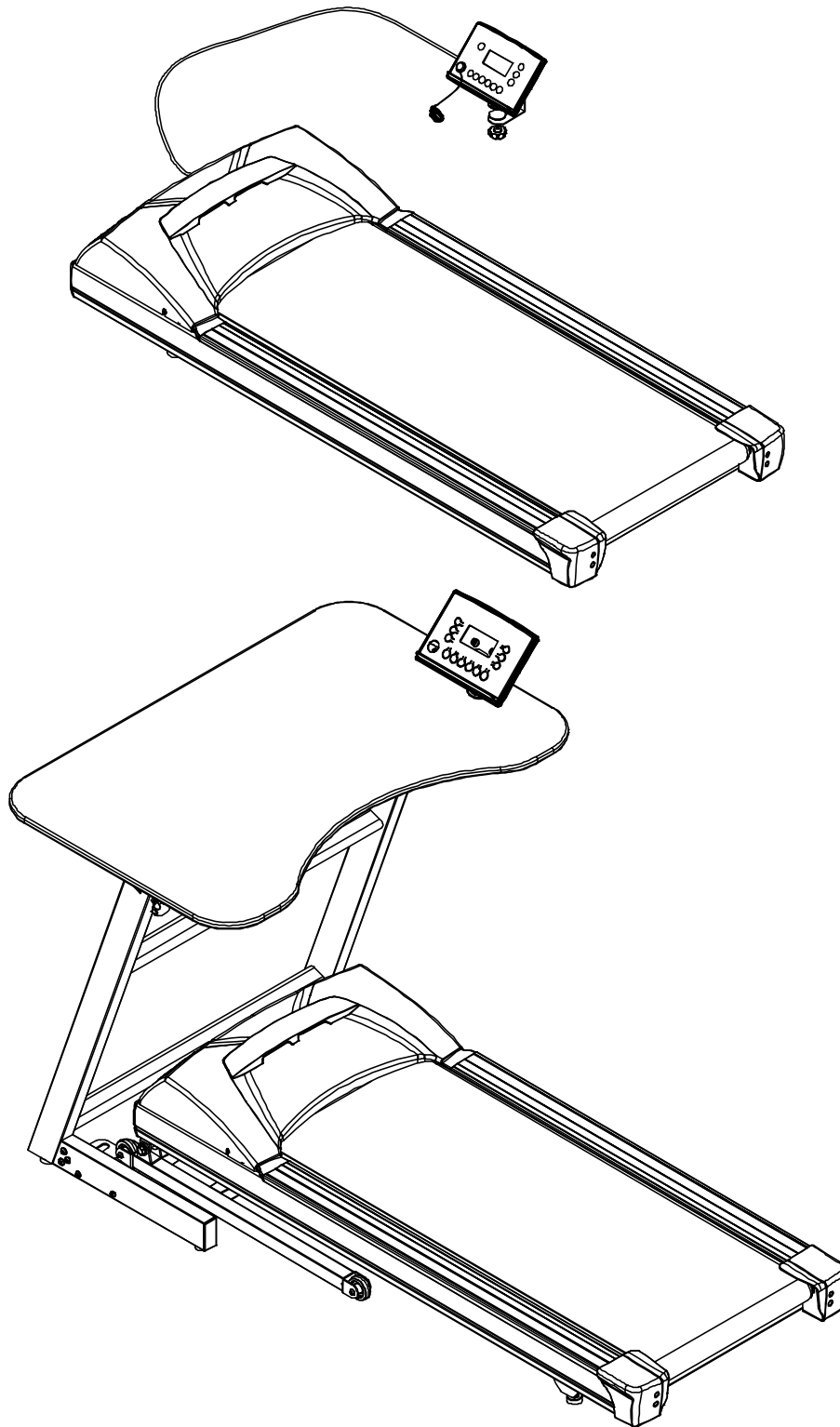

To adjust the distance between the desk and the treadmill, the user can adjust the position of the treadmill by moving the unit on the limit brackets to the desired position.

The console assembly can be secured on the desk after positioning the treadmill.

TREADMILL DESK FOLDING INSTRUCTIONS

Do not attempt to move the unit unless it is in the folded and locked position. Be sure the power cord and console cable are secured to avoid possible damage. Use both handrails to maneuver the unit to the desired position.

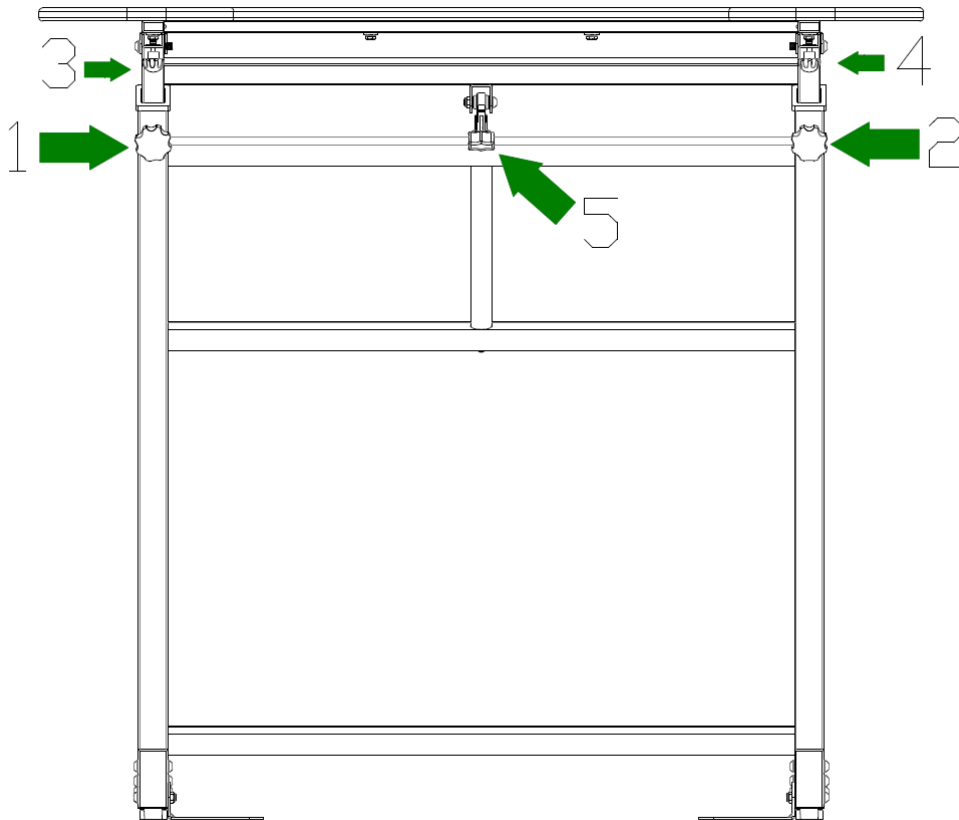

■ TO ADJUST THE DESK HEIGHT

Loosen the knobs (1&2) and press down on the handle of the hydraulic cylinder (5), the desk can be adjusted up or down to the desired height gently and then retighten the knobs (1&2).

■ TO FOLD/USE THE DESK

Note: Please check if the console has been secured on the desk or removed.

Loosen the knobs (3&4) and fold the desk back until the rubber foot pads are near the frame uprights. To use the desk pull down the desk table and secure the knobs (3&4) to lock the desk while in use.

FOLDING INSTRUCTIONS

■ TO FOLD THE TREADMILL

1. Disconnect the power cord and computer cable from the desk board stand.
2. Move the unit backward or fold the desk board then fold up the treadmill deck.
3. Lift the treadmill running deck until it is secured by the locking telescoping tube assembly in center back of base.

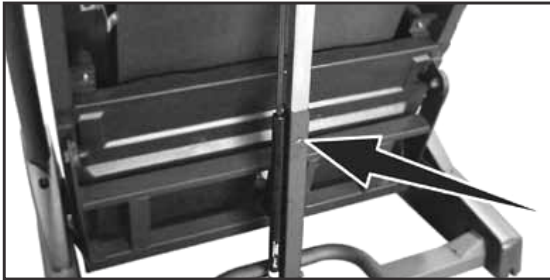

■ TO UNFOLD THE TREADMILL

Apply slight forward pressure* on the treadmill running deck with one hand. Pull down on the unlocking lever and slowly lower the running deck to the floor. The deck will lower unassisted when it reaches about waist high.

- *At the rear roller area to relieve pressure on the Locking system.

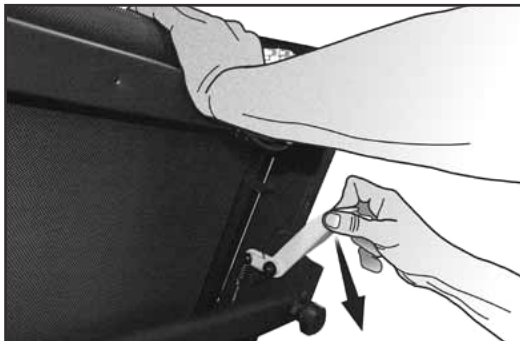

During installation, lay the treadmill deck under the desk with the transport wheels in the grooves of the limit brackets in order to secure the desk board stand.

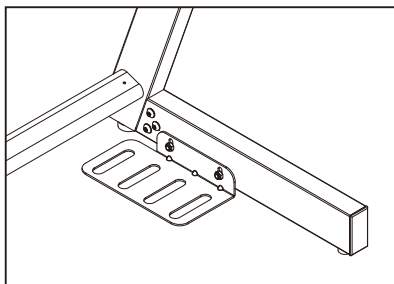

TRANSPORT INSTRUCTIONS

The treadmill is equipped with four transport wheels that are engaged when the treadmill is folded. After folding simply roll the treadmill away.

OPERATION OF YOUR TREADMILL

Getting familiar with the treadmill console controls



GETTING STARTED:

Power the treadmill on by plugging it into an appropriate wall outlet, then turn on the power switch located at the front of the treadmill below the motor hood. Ensure that the Safety Key is installed, as the treadmill will not operate without it.

When the power is turned on, the console will show the current software version, the total running mileage, hours. The treadmill will then enter idle mode, which is the starting point for operation.



CONSOLE OPERATION

START OPERATION

1. Attach the Safety key to enable the display (if not already on).
2. Press the **START** key to begin belt movement. Adjust to the desired speed using the **SPEED ▲/▼** keys. You may also use the **SPEED** keys **SLOW-MEDIUM-FAST** to adjust the speed.
3. To slow tread-belt press the **SPEED ▼** key to the desired speed.
4. To stop the tread-belt press the **STOP** key or pull away Safety key.

PAUSE/STOP/RESET FEATURE

1. When the treadmill is running the pause feature may be utilized by pressing the **STOP** key once. This will slowly decelerate the tread-belt to a stop. The Time, Distance and Calorie readings will hold while the unit is in the pause mode. After five minutes the display will reset and return to the start up screen.
2. To resume your exercise, when in Pause mode, press the **START** key. The speed will return to their previous settings.
 - Pause is executed when the **STOP** key is pressed once. If the **STOP** key is pressed a second time the program will end. If the **STOP** key is pressed a third time, the console will reset.

CALORIE DISPLAY

Displays the cumulative calories burned at any given time during your workout.

Note: This is only a rough guide used for comparison of different exercise sessions, which cannot be used for medical purposes.

TO TURN TREADMILL OFF

1. Remove tether cord.
2. Turn off the main switch on the front of the treadmill, below the motor cover.

TO TURN OFF AUDIBLE BEEP

1. If you want to turn off the audible beep sound that occurs when you press keys, etc., press the **MUTE** button on the top left of the console.

WINDOW DISPLAY

SCAN: Each parameter will take turns to display the exercising data for 5 seconds.

SPEED: Displays the current running speed from 0.8 KPH ~ 6.0 KPH.(0.5MPH~4.0MPH)

TIME: Accumulates total workout time from 00:00 to 99:59.

STEP: Accumulates total steps on training from 0 to 9999.

DISTANCE: Accumulates total workout distance from 0.00 to 99.99 Kilometers (99.99Miles).

CALORIES: Accumulates the user's calories consumption during exercise. Max. Value is 999.9 calories.

Note: This is only a rough guide used for comparison of different exercise sessions, which cannot be used for medical purposes.

FUNCTION BUTTON

ENTER: Press "ENTER" button to set the parameter of count down. When the belt stop running which press and hold this button for 3 seconds to reset all data which the parameter value of accumulating is. Use the "ENTER" button to confirm stride length setting.

START: Press "START" button to begin training.

- STOP:** Press "STOP" button to control stop training.
- SPEED ↑:** Press "FAST" button to increase your speed, each increment is 0.1KPH (0.1MPH).
- SPEED ↓:** Press "SLOW" button to decrease your speed, each decrement is 0.1KPH (0.1MPH).
- STRIDE LENGTH:** To set one step stride length, adjust the range from 30 ~ 99 centimeter. (See (SL.) page 19)
- DISPLAY:** To show workout information time, distance...etc..
- SAFETY KEY:** Attach the safety key in its position to power on the computer. When safety key is pulled away from its position, the computer will shut down automatically.

DIRECT SPEED KEYS:

3 preset buttons for direct speed: **1kph/1mph, 2kph/2mph, 3kph/3mph.**

User can press the 3 buttons, mentioned above, at any time, to start treadmill and treadmill will automatically adjust to press speed.

OPERATION (MANUAL):

- STEP 1:** Attach the **Safety key** to console then press any button to wake display up (**if not already on**), the screen will light up.
- STEP 2:** Press the **START** button to begin belt movement, before training; the console will be a 3 seconds final count down and a beep sound for short time. Using the **SPEED ↑ / ↓** keys to adjust the desired speed (on console) at any time during training.
- STEP 3:** Press **ENTER** button to see the value of parameter, which includes speed, time, distance, calories or scan. If chooses the scan mode that will take turns to display all value of parameter every 5 seconds.
- STEP 4:** While training, you can press **STOP** button to stop your workout or pull safety key away from its position to shut down the computer. If you want to resume your workout, you can press **START** button again and all previous data will resume counting.
- STEP 5:** After training, press **DISPLAY** button to display the accumulating data for speed, time, distance and calories that will be recorded during training. If you want to continue your workout, press **START** button to begin the treadmill again.

SETTING STRIDE LENGTH (S.L.):

Use the chart below for a quick guide to determine your stride length by using your height. While this is not as accurate as some other methods, it can give you a close estimate of your stride length. For a more accurate stride length, measure your walking step from toe to toe in CM. Enter that value to set Stride Length. Adjust desired stride length according to your preference.

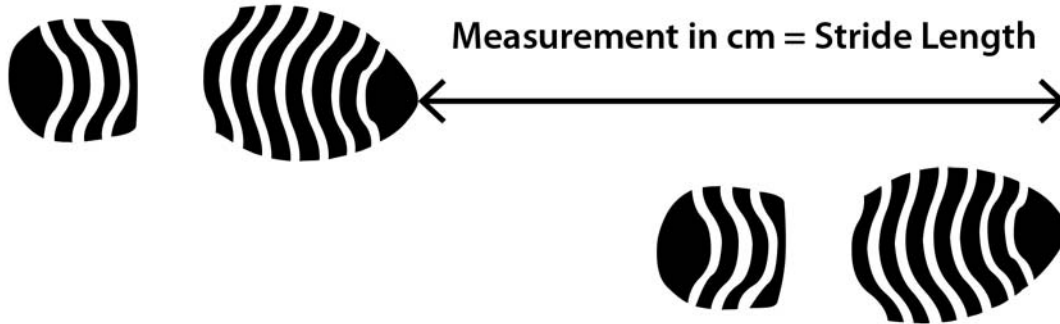

HEIGHT (CM)	STRIDE LENGTH (CM)
155 CM (5')	38
160 CM (5, 3")	40
165 CM (5, 5")	43
170 CM (5, 7")	45
175 CM (5, 9")	46
180 CM (5, 11')	47
185 CM (6')	49
190 CM (6, 2")	50
195 CM (6, 5')	52

GENERAL MAINTENANCE

⚠ WARNING: Always unplug your treadmill prior to cleaning in order to avoid electrical hazard or shock.

BELT & DECK

Your treadmill uses a very high-efficient low-friction deck. Performance is maximized when the deck is kept as clean as possible. Use a soft, damp cloth, or paper towel to wipe the edge of the belt and the area between the belt edge and the frame. Also reach as far as practical directly under the belt edge. This should be done once a month to extend belt and deck life. A mild soap and water solution along with a nylon scrub brush will clean the top of the textured belt. Allow to dry before using.

BELT DUST

This occurs during normal break-in or until the belt stabilizes. Sometimes the black dust from the belt will appear on the floor behind the treadmill, this is normal.

GENERAL CLEANING

Dirt, dust, and pet hair can block air inlets and accumulate on the running belt. Please vacuum underneath your treadmill on a monthly basis to prevent excess build-up of dirt that can get sucked up and get into the inner workings under the motor cover. Once a year, you should remove the black motor hood and vacuum out dirt that may accumulate. **UNPLUG POWER CORD BEFORE THIS TASK.** Cleaning metal surfaces may be accomplished by using a soft cotton or terry cloth rag with a light application of car wax. Do not use aerosol sprays or pump bottles as they may deposit wax upon the walking or computer surface. Under no circumstances are you to use ammonia, oils, silicones, or any other compounds on the rubberized walking surface. The use of such materials may cause serious injury to the body and/or deteriorate the performance of the walking surface. Only clean the rubberized walking surface with a damp cloth (water only). From time-to-time the computer surface may collect dust or finger prints. The use of harsh chemicals will destroy the protective coating and cause a static build up that will damage the components. This surface may be cleaned with specially prepared chemicals found in most computer supply stores especially made for anti-static surfaces. It is strongly recommended that you purchase such a cleaning compound.

BELT ADJUSTMENTS

Tread-belt Tension Adjustment - Belt tension is not critical for most users. It is very important for joggers and runners in order to provide a smooth, steady running surface. Adjustment must be made from the right and left side of the rear roller in order to adjust tension with the 6 mm Allen wrench provided in the parts package. The adjustment bolt is located at the end of the right and left side rails as noted in diagram below.

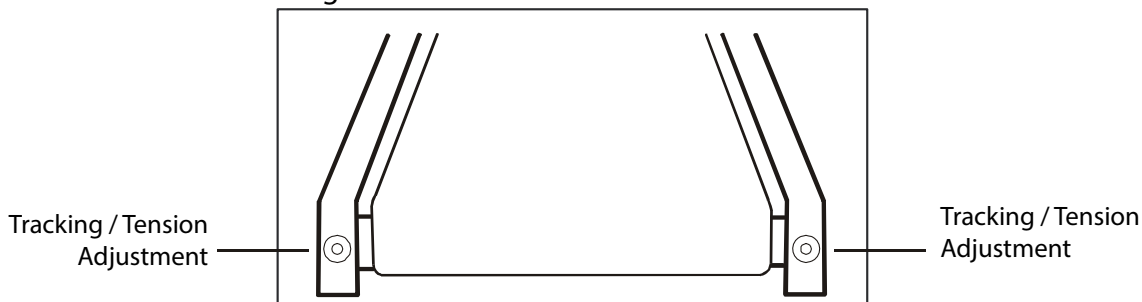

Note: Adjustment is through small hole in end cap.

Tighten the rear roller only enough to prevent slippage at the front roller. Turn the tread-belt tension adjusting bolt in increments of 1/4 turn and inspect for proper tension.

When an adjustment is made to the belt tension, you must also make a tracking adjustment to compensate for the change in belt tension. This is accomplished by turning both the tension and tracking Allen bolts an equal amount. This adjustment should be made by turning both bolts clockwise by no more than a 1/4 turn at a time.

DO NOT OVERTIGHTEN—Over tightening will cause belt damage and premature bearing failure. If you tighten the belt a lot and it still slips, the problem could actually be the drive belt-located under the motor cover - that connects the motor to the front roller. If that belt is loose it feels similar to the walking belt being loose. Tightening the motor belt should be done by a trained service person.

TREAD-BELT TRACKING ADJUSTMENT

The performance of your treadmill is dependent on the frame running on a reasonably level surface. If the frame is not level, the front and back roller cannot run parallel, and constant belt adjustment may be necessary.

The treadmill is designed so that the tread-belt remains reasonably centered while in use. It is normal for some belts to drift near one side while in use, depending on a user's gait and if they favor one leg. But if during use the belt continues to move toward one side, adjustments are necessary.

SETTING TREAD-BELT TRACKING

A 6mm Allen wrench is provided for this adjustment. Make tracking adjustments on the left side bolt. Set belt speed at 3 mph. Be aware that a small adjustment can make a dramatic difference which may not be apparent right away. If the belt is too close to the left side, then turn the bolt only a 1/4 turn to the right (clockwise) and wait a few minutes for the belt to adjust itself. Continue to make 1/4 turns until the belt stabilizes in the center of the running deck.

If the belt is too close to the right side, turn the bolt counter-clockwise. The belt may require periodic tracking adjustment depending on use and walking/running characteristics. Some users may affect tracking differently. Expect to make adjustments as required to center the tread-belt. Adjustments will become less of a maintenance concern as the belt is used. Proper belt tracking is an owner responsibility common with all treadmills.

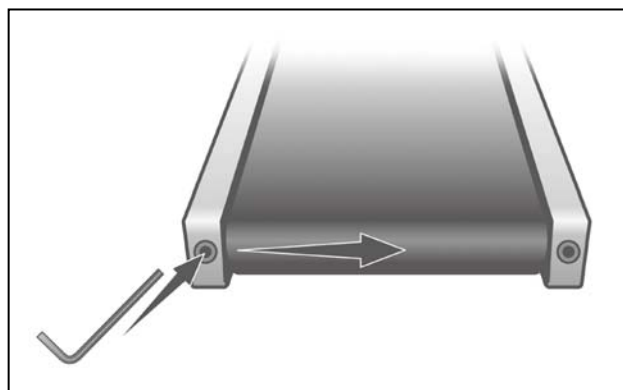

ATTENTION:

DAMAGE TO THE RUNNING BELT RESULTING FROM IMPROPER TRACKING / TENSION ADJUSTMENTS IS NOT COVERED UNDER THE WARRANTY.

TREADMILL BELT

The walking belt on your new SOLE treadmill is made of the highest quality materials designed to last even under punishing conditions. When a treadmill belt is brand new, and has been in the package for a few months before use, a common occurrence can happen; the area of the belt that wraps around the rollers will take on the shape of the roller. Upon starting the treadmill this shape in the belt causes a thumping sound each time the belt moves past the rollers. Once the treadmill has been used for a few workouts, the belt wears in and the thumping sound goes away. This noise is normal on new higher end belts so there is no need to contact service; the new belt just requires a wear in period. Thank you for choosing SOLE and enjoy your new treadmill.

BELT/DECK LUBRICATION

First, you want to clean between the belt and deck to remove any debris that may be trapped. Use a clean, non-fraying rag, t-shirt, or light towel. Halfway between the end of the treadmill and motor cover, shove the garment under the belt until you can grasp it on both sides of the belt. Drag the garment the length of the entire belt 1-2 times. Remove the garment.

Only lubricate your treadmill with 100% silicone treadmill lubricant. Your treadmill comes with one tube of "Lube" and extra tubes can be ordered directly from Dyaco Canada Inc. or your authorized Sole Fitness dealer. You may also use a Lube-n-Walk kit that can be purchased through both aforementioned sellers.

Keeping the deck lubricated at the recommended intervals ensures the longest life possible for your treadmill. If the lubricant dries out, the friction between the belt and deck rises and places undue stress on the drive motor, drive belt and electronic motor control board, which could result in catastrophic failure of these expensive components. Failure to lubricate the deck at regular intervals may void the warranty.

The belt & deck come pre-lubricated and subsequent lubrication should be performed every 90 hours of use or if you notice that the deck is dry. It is recommended that you reach between the belt and deck to verify there is lubrication present, every other month. If you check and there isn't any lubrication present, follow the procedure below even though the "Lube" indicator isn't lit on the console. Otherwise, lubricate when the console's lubrication reminder lights after 90 hours of use. Use the following procedure to apply the silicone lubricant:

1. Turn the power switch off and unplug the power cord from the wall outlet.
2. Measure 18" from the edge of the motor cover; kneel down and reach under the belt approximately 4-6" from one edge. Squirt a line of lubricant about 1/8" wide x 15" long in an "S" pattern perpendicular to the motor cover.
3. Repeat the process on the opposite side.
4. Plug the electrical cord back into the outlet and turn the power switch on.
5. Walk on the belt at a moderate speed for five minutes to evenly distribute the silicone lube.

SERVICE CHECKLIST – DIAGNOSIS GUIDE

Before contacting your dealer for aid, please review the following information. It may save you both time and expense. This list includes common problems that may not be covered under the treadmill's warranty.

PROBLEM	SOLUTION/CAUSE
Display does not light up	<ol style="list-style-type: none"> 1. Tether cord not in position. 2. Circuit breaker on front grill tripped. Push circuit breaker in until it locks. 3. Plug is disconnected. Make sure plug is firmly pushed into AC wall outlet. 4. Circuit breaker may be tripped. 5. Treadmill defect. Contact your dealer.
Tread-belt does not stay centered Treadmill belt hesitates when walked/run on	<p>The user may be walking while favoring or putting more weight on either the left or right foot. If this walking pattern is natural, track the belt slightly off-center to the side opposite from the belt movement. See General Maintenance section on Tread-belt Tension. Adjust as necessary.</p>
Motor is not responsive after pressing start	<ol style="list-style-type: none"> 1. If the belt moves, but stops after a short time and the display shows "LS", run calibration or check the speed sensor. 2. If you press start and the belt never moves, then the display shows LS, contact service.
Treadmill will only achieve approximately 5 kph (3 mph) but shows higher speed on display	<p>This indicates motor should be receiving power to operate. Low AC voltage to treadmill. Do not use an extension cord. If an extension cord is required it should be as short as possible and heavy duty 16 gauge minimum. Low voltage. Contact an electrician or your dealer. A minimum of 120 volt ac is required.</p>
Tread-belt stops quickly/suddenly when tether cord is pulled	<p>High belt/deck friction. See General Maintenance section on lubrication.</p>
Treadmill trips on board 15 amp circuit	<p>High belt/deck friction. See General Maintenance</p>
Computer shuts off when console is touched (on a cold day) while walking/running	<p>Treadmill may not be grounded. Static electricity is "crashing" the computer. Refer to Grounding Instructions.</p>
Circuit breaker trips, but not the treadmill circuit breaker	<p>Need to replace the breaker with a "High In-rush current" type breaker.</p>

CALIBRATION PROCEDURE

1. Remove the **Safety Key**.
2. Press and hold down the **Start** and **Fast** buttons and replace the **Safety Key**, then press the **Enter** key.
3. You will now be able to set the display to show mile or km settings (Miles vs. Kilometers), and check the wheel size. To do this, press the **Fast /Slow** key to show which you want, then press **Enter**.
4. Adjust the minimum speed (if needed) to 0.8kph/0.5mph and then press **Enter**.
5. Adjust the maximum speed (if needed) to 6.0kph/4.0mph
6. Press **Start** to begin calibration. The process is automatic; the speed will start up without warning, so do not stand on the belt.

ADJUSTING THE SPEED SENSOR

If the calibration does not pass you may need to check the speed sensor alignment.

1. Remove the motor cover hood by loosening the 4 screws that hold it in place (you do not need to remove them completely).
2. The speed sensor is located on the left side of the frame, right next to the front roller pulley (the pulley will have a belt around it that also goes to the motor). The speed sensor is small and black with a wire connected to it.

Make sure the sensor is as close as possible to the pulley without touching it. You will see a magnet on the face of the pulley; make sure the sensor is aligned with the magnet. There is a screw that holds the sensor in place that needs to be loosened to adjust the sensor. Re-tighten the screw when finished.

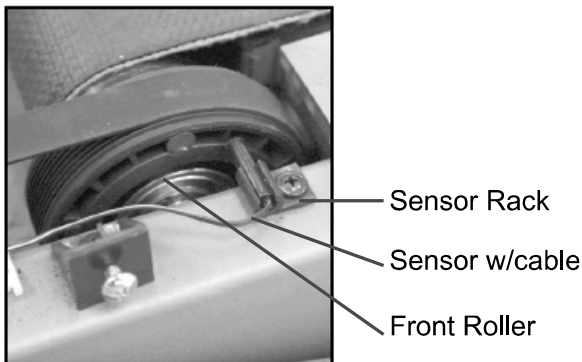

ERROR MESSAGE:

1. **LS:** Treadmill doesn't receive the speed signal for 8 seconds.
2. **E1:** Memory of console malfunction or CPU accessing problem.

MANUFACTURER'S LIMITED WARRANTY

TREADMILL WARRANTY

Effective February 1,
2019

SOLE warrants all its treadmills' parts, for a period of time listed below, from the date of retail sale, as determined by sale receipt, or in the absence of a receipt eighteen (18) months from the original factory shipping date. SOLE's responsibilities include providing new or remanufactured parts, at SOLE's option, and technical support to our independent dealers and servicing organizations. In the absence of a dealer or service organization, these warranties will be administered by SOLE directly to a consumer. The warranty period applies to the following components:

Drive Motor	Lifetime
Deck	3 Years
All Other Components	3 Years
Frame Weldments	Lifetime
Labor	1 Year
Cosmetic Items *	90 Days

*Cosmetic items including, but not limited to the following: grips, console overlays, and labels/decals

NORMAL RESPONSIBILITIES OF THE CONSUMER

This warranty applies only to products in ordinary household use, and the consumer is responsible for the items listed below:

1. The warranty registration card must be completed and returned to the address listed on the card within 10 days of the original purchase to validate the manufacturer's limited warranty.
2. Proper use of the treadmill in accordance with the instructions provided in this manual, including belt tracking.
3. Proper installation in accordance with instructions provided with the treadmill and with all local electric codes.
4. Proper connection to a grounded power supply of sufficient voltage, replacement of blown fuses, repair of loose connections or defects in house wiring.
5. Expenses for making the treadmill accessible for servicing, including any item that was not part of the treadmill at the time it was shipped from the factory.
6. Damages to the treadmill finish during shipping, installation or following installation.
7. Routine maintenance of this unit as specified in this manual.

EXCLUSIONS

This warranty does not cover the following:

1. CONSEQUENTIAL, COLLATERAL, OR INCIDENTAL DAMAGES SUCH AS PROPERTY DAMAGE AND INCIDENTAL EXPENSES RESULTING FROM ANY BREACH OF THIS WRITTEN OR ANY IMPLIED WARRANTY.
Note: Some states do not allow the exclusion or limitation of incidental or consequential damages, so this limitation or exclusion may not apply to you.
2. Service call reimbursement to the consumer. Service call reimbursement to the dealer that does not involve malfunction or defects in workmanship or material, for units that are beyond the warranty period, for units that are beyond the service call reimbursement period, for treadmill not requiring component replacement, or treadmill not in ordinary household use.
3. Damages caused by services performed by persons other than authorized SOLE service companies; use of parts other than original SOLE parts; or external causes such as corrosion, discoloration of paint or plastic, alterations, modifications, abuse, misuse, accident, improper maintenance, inadequate power supply, or acts of God.
4. Products with original serial numbers that have been removed or altered.
5. Products that have been: sold, transferred, bartered, or given to a third party.
6. Products that do not have a warranty registration card on file at SOLE. SOLE reserves the right to request proof of purchase if no warranty record exists for the product.
7. THIS WARRANTY IS EXPRESSLY IN LIEU OF ALL OTHER WARRANTIES EXPRESSED OR IMPLIED, INCLUDING THE WARRANTIES OF MERCHANTABILITY AND/OR FITNESS FOR A PARTICULAR PURPOSE.
8. Product use in any environment other than a residential setting.
9. Warranties outside of North America may vary. Please contact your local dealer for details.

SERVICE

Keep your bill of sale. Twelve (12) months from the date on the bill of sale or eighteen (18) months from the date of factory shipping as determined by the serial number establishes the labor warranty period should service be required. If service is performed, it is in your best interest to obtain and keep all receipts. This written warranty gives you specific legal rights. You may also have other rights that vary from state to state. Service under this warranty must be obtained by following these steps, in order:

1. Contact your selling authorized SOLE dealer. OR
2. Submit all service requests including serial number, contact information and a brief description of the problem online at <http://www.soletreadmills.com/serviceparts.html>
3. If you have any questions about your new product or questions about the warranty contact SOLE Fitness at 1-866-780-SOLE (7653). If you have a technical problem with your new treadmill contact SOLE technical service at 866-MYSOLE1 (697-6531).
4. If no local service is available, SOLE will repair or replace the parts, at SOLE's option, within the warranty period at no charge for parts. All transportation costs, both to our factory and upon return to the owner, are the responsibility of the owner. The owner is responsible for adequate packaging upon return to SOLE. SOLE is not responsible for damages that occur during shipping. Make all freight damage claims with the appropriate freight carrier. DO NOT SHIP ANY UNIT TO OUR FACTORY WITHOUT A RETURN AUTHORIZATION NUMBER. All units arriving with- out a return authorization number will be refused.
5. For any further information, or to contact our service department by mail, send your correspondence to:
SOLE Fitness
PO. Box 2037
Jonesboro, AR 72402-2037

Product features or specifications as described or illustrated are subject to change without notice. All warranties are made by SOLE.

Before returning your Sole product to any retailer, or if you require any assistance with assembly or technical support please call us first for assistance at 866-697-6531. Thank you for your Sole purchase.

SOLE[™]
FITNESS