

**SOLE**<sup>™</sup>  
FITNESS

**OWNER'S MANUAL**  
**SB900 Indoor Cycle**

*Please carefully read this entire manual  
before operating your new indoor cycle.*

**ATTENTION:** *Before returning your Sole product to any retailer, or if you require any assistance with assembly or technical support please call us first for assistance at 866-697-6531. Thank you for your Sole purchase.*

# TABLE OF CONTENTS

<u>Product Registration</u>	<u>1</u>
<u>Important Safety Instructions</u>	<u>2</u>
<u>Important Operation Instructions</u>	<u>2</u>
<u>SB900 Assembly Instructions</u>	<u>4</u>
<u>Operation of Your New Indoor Cycle</u>	<u>8</u>
<u>Manufacturer's Limited Warranty</u>	<u>16</u>



**WARNING:** This product can expose you to chemicals including Toluene and Acrylamide which are known to the State of California to cause Cancer and birth defects or other reproductive harm. For more information, go to [www.P65Warnings.ca.gov](http://www.P65Warnings.ca.gov)

**Before returning your Sole product to any retailer, or if you require any assistance with assembly or technical support please call us first for assistance at 866-697-6531. Thank you for your Sole purchase.**

# SOLE

## FITNESS

### CONGRATULATIONS ON YOUR NEW INDOOR CYCLE AND WELCOME TO THE SOLE FAMILY!

Thank you for your purchase of this quality indoor cycle from **SOLE**. Your new indoor cycle has been manufactured by one of the leading fitness manufacturers in the world and is backed by one of the most comprehensive warranties available. **SOLE** will do all we can to make your ownership experience as pleasant as possible for many years to come.

If you have any questions about your new product or questions about the warranty contact **SOLE** Fitness at **1-866-780-SOLE (7653)**. If you have a technical problem with your new indoor cycle contact **SOLE** technical service at **866-MYSOLE1 (1-866-697-6531)**.

Please take a moment at this time to record below the name of the dealer, their telephone number, and the date of purchase for easy contact in the future. We appreciate your confidence in **SOLE** and we will always remember that you are the reason that we are in business. Please complete and mail your registration card today and enjoy your new indoor cycle.

Yours in Health,  
**SOLE** Fitness

Name of Dealer \_\_\_\_\_

Telephone Number of Dealer \_\_\_\_\_

Purchase Date \_\_\_\_\_

## PRODUCT REGISTRATION

### RECORD YOUR SERIAL NUMBER

Please record the Serial Number of this fitness product in the space provided below.

Serial Number \_\_\_\_\_



### REGISTER YOUR PURCHASE

The self-addressed product registration card must be completed in full and returned to **SOLE**. You can also go to [www.soletreadmills.com](http://www.soletreadmills.com) under the support tab to register online.

# IMPORTANT SAFETY INSTRUCTIONS

**WARNING** - Read all instructions before using this appliance.

1. Use this equipment only for its intended use as described in this manual. Do not attempt to ride this bike at high pedal speeds until you have ridden the bike for some time and are comfortable riding at slower pedal speeds.
2. The bike is NOT equipped with a freewheel system which means that when the flywheel is in motion, the pedals will be in motion. Do not attempt to stop the unit by applying backward pressure to pedals while they are turning as knee injury may occur. Do not attempt to remove your feet from pedals while they are moving.
3. Wait for flywheel to coast to a stop before dismounting the bike. If you want to stop the flywheel, push down on the brake knob.
4. Serious injury or death may occur from over-training. Consult a medical doctor or qualified fitness instructor to determine an exercise program appropriate for your level of fitness.
5. Do not attempt to turn the pedal cranks by hand. Do not touch any driving mechanism while it is in motion as possible injury could occur.
6. In a home setting, keep children away from the bike when it is not in use. Keep children and pets away from the unit while it is in use.
7. Do not attempt to perform dip movements on handlebars.
8. Never drop or insert any object into any opening of the bike.
9. Only use the bike on a stable, level floor.
10. Follow instructions for safe use of the equipment including proper seat position, handlebar position, and use of foot positioning system of pedals. Do not attempt to pull up handlebar post and seat post over the 'MAX.' graduation.
11. For safe operation, allow for at least 1foot (30cm) of free space to either side of the unit and 2 feet (60cm) of free space to the rear of the unit.

Regularly examine the bike for damage and wear. Inoperable components should be replaced immediately or the equipment should not be used until it is repaired.

Failure to follow all guidelines may compromise the effectiveness of the exercise experience, expose yourself (and possibly others) to injury, and reduce the longevity of the equipment.

**SAVE THESE INSTRUCTIONS - THINK SAFETY!**

# IMPORTANT OPERATION INSTRUCTIONS

**WARNING** - AS THE OWNER OF THIS EXERCISE EQUIPMENT, YOU SHOULD INSIST THAT ALL USERS FOLLOW THE SAME GUIDELINES: YOU SHOULD MAKE THIS MANUAL AVAILABLE TO ALL USERS.

1. Obtain a complete physical examination from your medical doctor and enlist a health/ fitness professional's aid in developing an exercise program suitable for your current health status.
2. When working out for the first time, start out slowly for a minimum of five minutes. After your muscles are warmed up, gradually increase the pedaling speed and/or resistance.
3. The speed and duration of your exercise program should always be subject to how you feel. Never permit peer pressure to exceed your personal judgment while exercising.
4. Overweight or severely de-conditioned individuals should be particularly cautious when using the equipment for the first time. Even though such individuals may not have histories of serious physical problems, they may perceive the exercise to be far less intense than it really is, resulting in the possibility of overexertion or injury.
5. Proper installation and regular maintenance are required to ensure user's safety. Maintenance is the sole responsibility of the owner.

# SB900 ASSEMBLY PACK CHECKLIST

## 1 HARDWARE STEP 1



**#82.** 3/8"  
Nut (4 pcs)

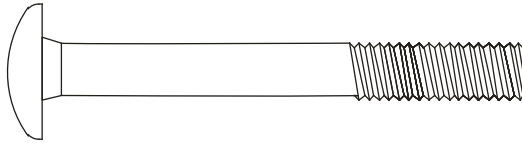

**#81.** 3/8" x 3-1/2"  
Button Head Socket Bolt (4 pcs)

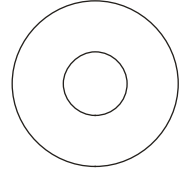

**#83.** 3/8" x 23mm  
Curved Washer (4 pcs)

## 2 HARDWARE STEP 2

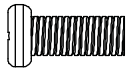

**#91.** M5 x 10mm  
Screw (2 pcs)

## 3 HARDWARE STEP 3

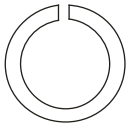

**#49.** ø8  
Split Washer (4 pcs)

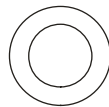

**#48.** ø8 x 16mm  
Flat Washer (4 pcs)



**#88.** M8 x P1.25 x 20L  
Screw (4 pcs)

## 5 HARDWARE STEP 5

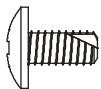

**#93.** M5 x 12L\_  
Tapping Screw (2 pcs)

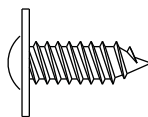

**#101.** 4 x 16L\_  
Sheet Metal Screw (3 pcs)

## ASSEMBLY TOOLS

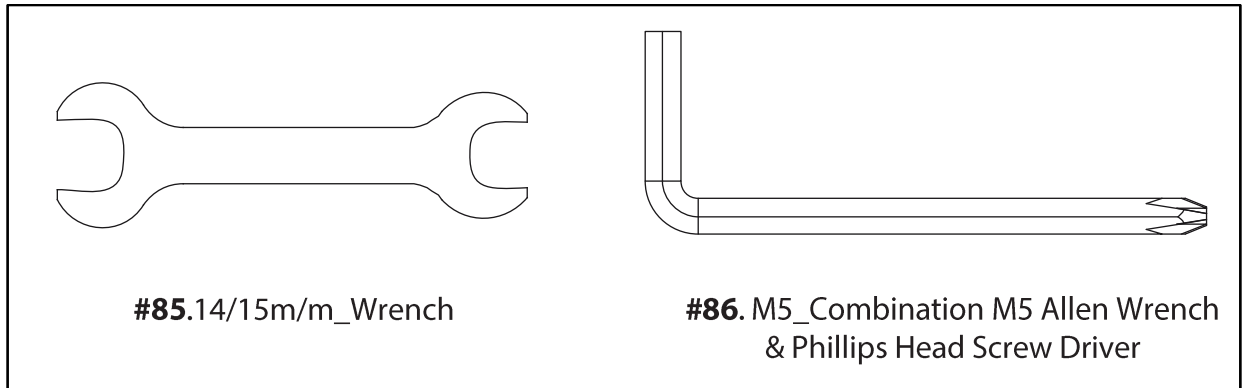

# SB900 ASSEMBLY INSTRUCTIONS

## PRE-ASSEMBLY

1. Using a razor knife (Box Cutter) cut the outside, bottom, edge of box along the dotted Line. Lift Box over the unit and unpack.
2. Carefully remove all parts from carton and inspect for any damage or missing parts. If damaged parts are found, or parts are missing, contact your dealer immediately.
3. Locate the hardware package. Remove the tools first. Remove the hardware for each step as needed to avoid confusion. The numbers in the instructions that are in parenthesis (#) are the item number from the assembly drawing for reference.

# 1 STABILIZER TUBES

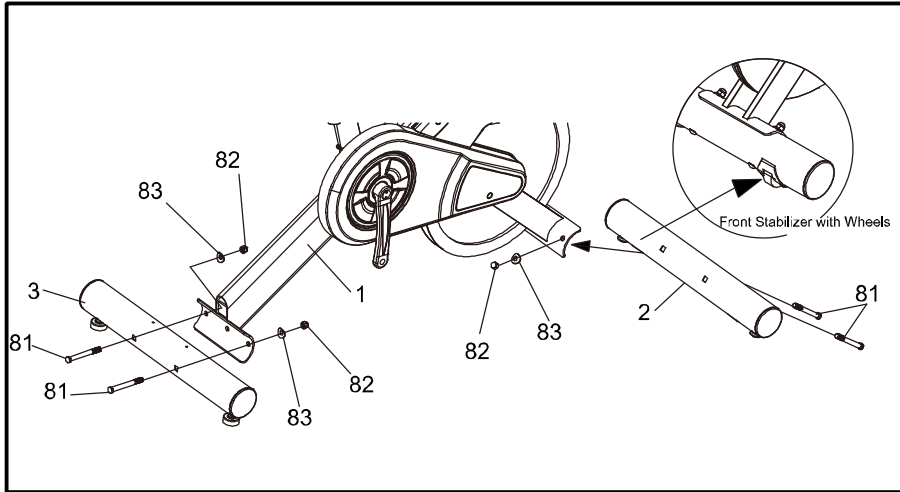

## HARDWARE STEP 1

- #82. 3/8" Nut (4 pcs)
- #81. 3/8" x 3-1/2" Button Head Socket Bolt (4 pcs)
- #83. 3/8" x 23mm Curved Washer (4 pcs)

1. Install the front and rear stabilizers with four Button Head Socket Bolts (**81**), four Curved Washers (**83**) and four Nuts (**82**). The front and rear stabilizer are different. Be sure to assemble the stabilizer with the wheels onto the front of the bike.

# 2 REAR STABILIZER COVER

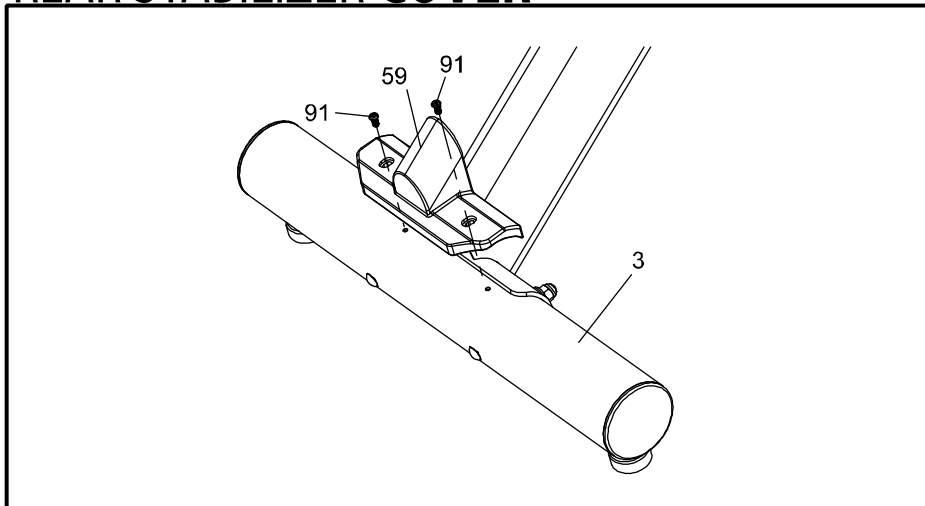

## HARDWARE STEP 2

- #91. M5 x 10mm Screw (2 pcs)

1. Install the rear stabilizer cover with two Phillips Head Screws (**91**).

# 3 HANDLEBAR

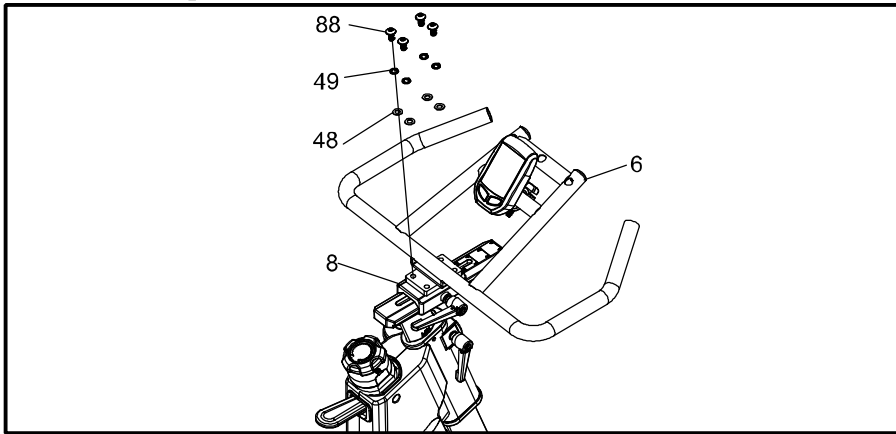

## HARDWARE STEP 3

- #49.  $\varnothing 8$  Split Washer (4 pcs)
- #48.  $\varnothing 8 \times 16\text{mm}$  Flat Washer (4 pcs)
- #88.  $M8 \times P1.25 \times 20L$  Button Head Socket Bolts (4 pcs)

1. Install the handlebars with four Button Head Socket Bolts (**88**), Split Washers(**49**) and Flat Washers (**48**). Tighten the bolts securely.

# 4 LEFT/RIGHT PEDALS

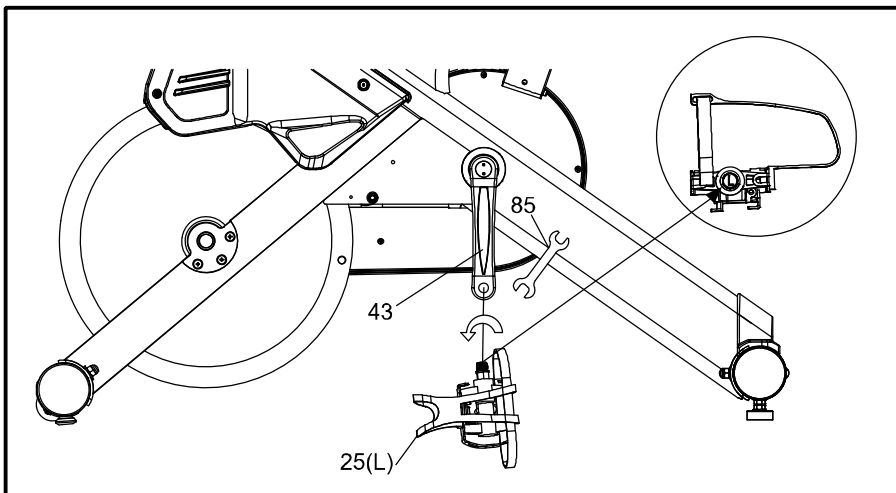
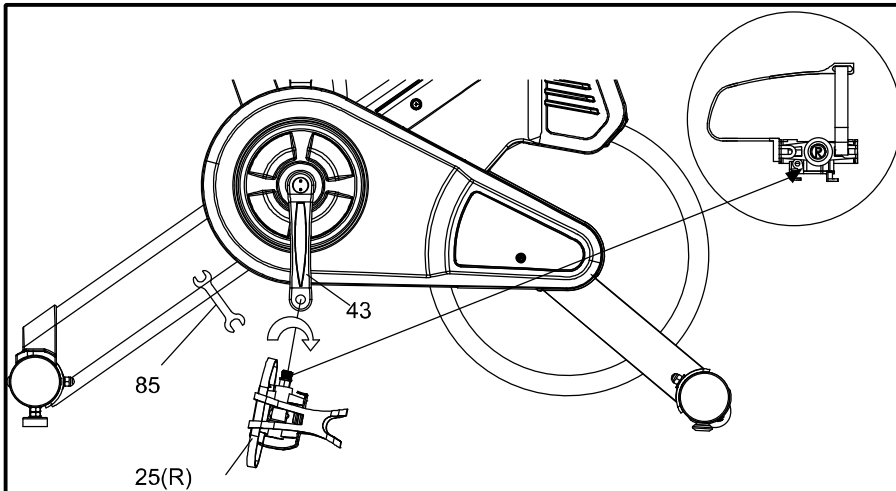

1. Install the Left (**25L**) and Right (**25R**) pedals to the crank arms. Please note that the Left pedal has a reverse threaded bolt and needs to be tightened in a counterclockwise direction. The pedals are identified by either an R or L stamped into the end of the bolt.



# 5 TABLET HOLDER

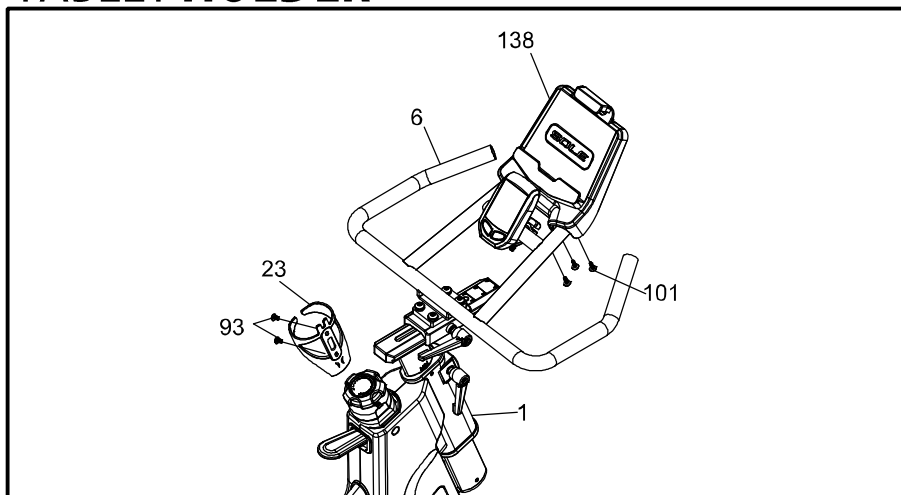

## HARDWARE STEP 5

- #93. M5 × 12L\_  
Tapping Screw (2 pcs)
- #101. 4 × 16L\_  
Sheet Metal Screw  
(3 pcs)

1. Install the Tablet Holder (**138**) on the Handlebar (**6**) with 3pcs of 4 x 16m/m Sheet Metal Screws (**101**) by using the M5\_Combination M5 Allen Wrench & Phillips Head Screw Driver (**86**)

# OPERATION OF YOUR INDOOR CYCLE

## GETTING FAMILIAR WITH THE CONTROL PANEL

### SB900 CONSOLE

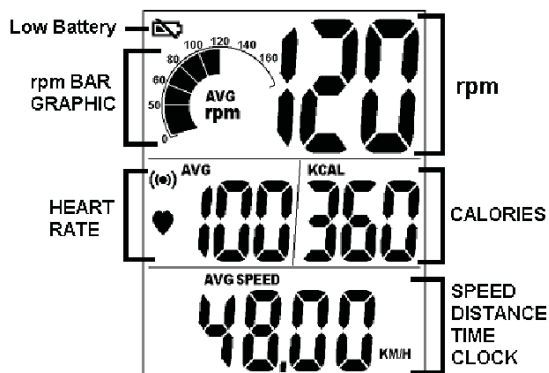

#### PLEASE NOTE:

1. The Sole Indoor Cycling Console system is designed as a sealed unit and not meant to be opened other than for the sole purpose of installing batteries. Any opened units will void the warranty.
2. To clean the Sole Indoor Cycling Console use a clean damp cloth. Use of any caustic cleaning solutions will void the warranty.
3. The Sole Indoor Cycling Console system is NOT waterproof, only water resistant. Any excessive exposure to water will void the warranty.

The Sole Indoor Cycling Console carton consists of a computer console and a speed sensor transmitter. The transmitter counts the number of times the magnet, which is mounted on the crank assembly, passes the sensor. The speed sensor transmitter will then send a coded signal to the console which contains the measured value (Speed and Cadence).

# CONSOLE OPERATION

## TIME

Time is measured in min:sec. There is a time of day clock and a workout timer clock. The workout time will count up or count down during pedaling. If pedaling stops, the time will stop counting after 3sec.

## RPM/CADENCE

Cadence is the measurement of how fast the cranks are rotating in RPM. The approximate speed of the bike can also be displayed in MPH or KPH. In addition to MPH/KPH, the RPM section of the display also has a bar graph that allows the rider to visually keep track of the approximate RPM.

## DISTANCE

Distance is the measurement of the virtual distance traveled on the bike. This distance is based on the user riding a bike with tires that are the same size as the Sole group bike's flywheel.

## KCAL

Kcal is the approximation of calories burned during your work out. The calories are an estimate only.

## HEART RATE

This is the approximation of heart rate detected from the chest strap (sold separately) during your work out.

## Changing from metric to standard data or vice versa

Note: you will have to press the buttons fairly quickly or the screen will return to the prior setting.

1. Press the left key repeatedly until workout DISTANCE is displayed
2. Press and hold the right key down until workout TIME is displayed
3. Press the left key 4x
4. Press the right key one time
5. Press the left key one time
6. Press and hold the left key down until the switch is complete

## QUICK START

When the console is in Power Saving Mode, hold down any key to wake up the console and go to the start-up screen, also called "QUICK Start" active state.

**POWER SAVING MODE**

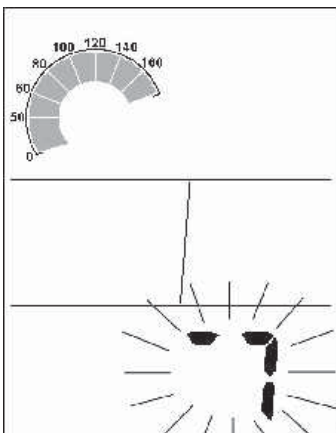

**QUICK START MODE**

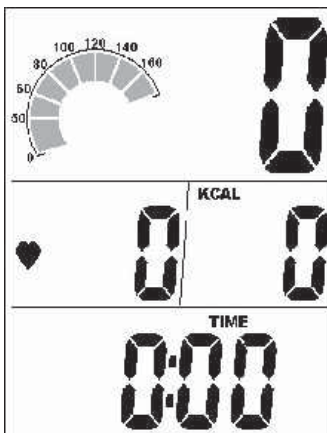

## MODE SELECT

Press the left hand key to select the SPEED, DIST, TIME or CLOCK at the bottom of the display.

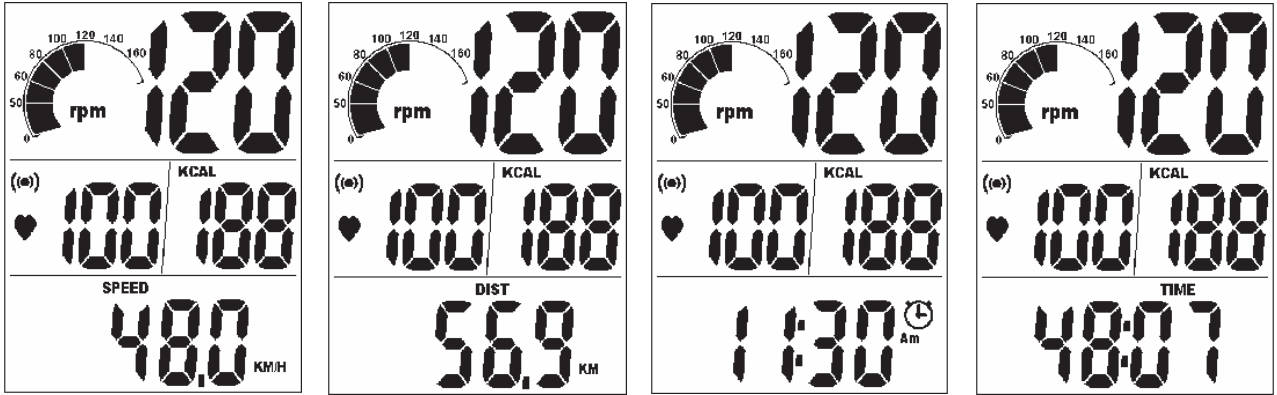

## RESET/HEART RATE ALARM SELECT

1. Press the right hand key to activate the heart rate (this will only register if you are wearing the chest strap which is sold separately). If the alarm is on, the alarm icon will flash and a beep will sound to indicate that your heart rate is either above or below the selected target zone.
2. To clear exercise TIME, AVG SPEED, AVG PULSE, DISTANCE, and KCAL, press the left key until TIME is displayed, then press and hold the right key until data is reset.

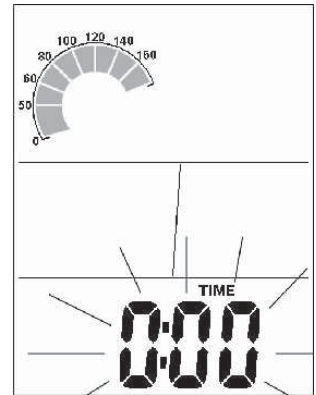

## HEART RATE TARGET ZONES

1. Press the left hand key until 'SPEED' is displayed, then hold the right hand key for 3 seconds. The TIME will be flashing; press the left hand key to select the heart rate target zone settings.
2. Press the right hand key to increase maximum heart rate limit. After setting the maximum heart rate, press the left hand key to adjust the minimum heart rate limit.

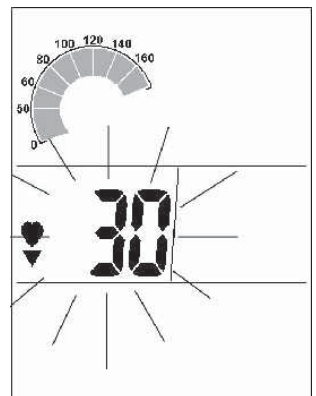
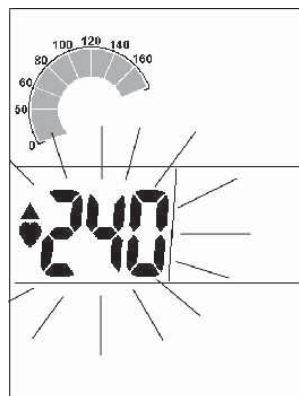

## HEART RATE TARGET ZONES

1. GENDER: Press the left hand key until SPEED is displayed, then press the right hand key for 3 seconds. The TIME will be flashing, press the left hand key until the gender icon is blinking. Press the right hand key to select gender.
2. Press the left hand key to set the measuring value for weight (Lb or Kg); press the right hand key to select.
3. BODYWEIGHT: Press the left hand key to set the bodyweight. Press the right hand key to increase the weight. Press and hold the right hand key for rapid advance.

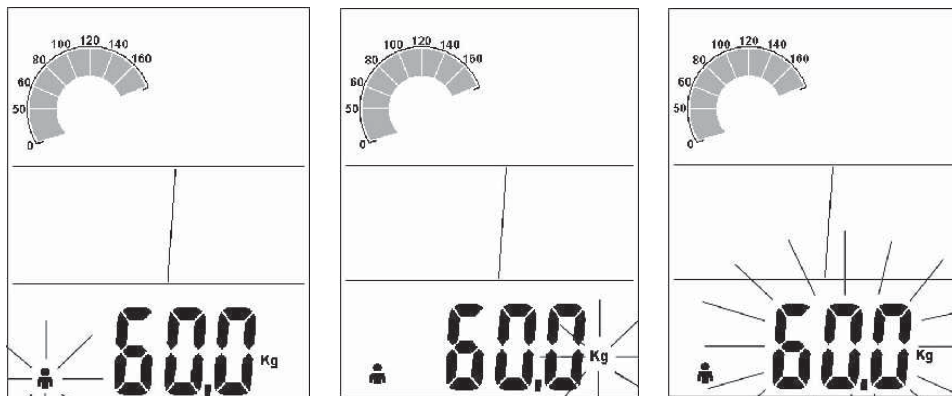

## BASIC OPERATION

Now that you have established a proper riding position, take a few minutes to ride the bike and determine that your position is comfortable. Start pedaling at a slow pace with your toes and knees pointed directly forward. Hold the handlebar lightly and in a position that allows your shoulders and upper body to relax. Pedal easily, at a low resistance until you feel confident that you could ride in that position for the duration of your workout.

### WARNING!

IF AT ANY TIME DURING YOUR WORKOUT, YOU FEEL CHEST PAIN, EXPERIENCE SEVERE MUSCULAR DISCOMFORT, FEEL FAINT, OR ARE SHORT OF BREATH, STOP EXERCISING AT ONCE. IF THE CONDITION PERSISTS, YOU SHOULD CONSULT YOUR MEDICAL DOCTOR IMMEDIATELY.

1. Pedaling resistance is controlled by the tension knob. Resistance can be changed at any time by turning tension knob: clock-wise for more resistance; counterclockwise for less resistance.
2. To apply the brake, press down on the tension knob.
3. Before dismounting, apply the brake to stop flywheel, or increase resistance and let flywheel come to a stop.

# FIRST TIME USER INSTRUCTIONS

## ADJUSTING THE BIKE FOR A PROPER FIT

Take some time to learn how to properly adjust the bike to your body; it will make your workouts more pleasant and a safer experience too. Riding the bike when it is incorrectly adjusted can result in discomfort and increase your risk of injury.

### ADJUSTMENT OF SEAT POSITION

#### Seat Height Adjustment

1. Standing next to the bike, adjust the seat until it is about hip height.
2. Rotate the crank arms until the pedals are in the vertical position: 12 and 6 o'clock.
3. Place your foot in the toe cage of the pedal closest to the floor and mount the bike. Ensure that the ball of your foot is over the center of the pedal. Your leg should be slightly bent at the knee, about 5 degrees.
4. If your leg is too straight or your foot cannot touch the pedal you will need to lower the seat height. If your leg is bent too much, you will need to raise the seat height.
5. Dismount the bike. Then loosen the quick release lever on the seat post and adjust up or down as necessary.
6. When the seat is in the desired position, tighten the quick release to secure the seat post.
7. Note the final position mark on the seat post for future reference.

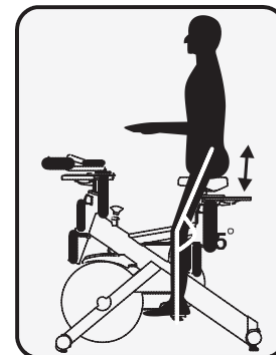

#### Seat Forward/Aft Adjustment

8. Sit on the bike with the crank arms in the 3 and 9 o'clock positions. A proper forward/aft position (for road bike training) of the seat is achieved when the small bump at the top of your shin is above the pedal axle.
9. Dismount the bike. Loosen the quick release under the seat and slide the seat forward or backward as desired; tighten the quick release lever.

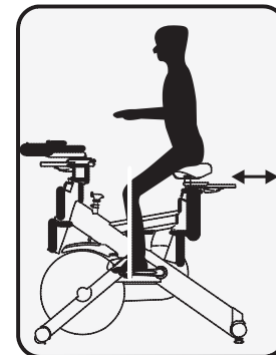

### HANDLE BAR ADJUSTMENT

#### Handlebar Height Adjustment

1. The handlebar height is a matter of preference. Start with a handlebar height that is the same as the seat's height. Adjusting the handlebar higher will give the rider a more upright position; lower will result in a more crouched position.
2. Raise or lower the handlebar by loosening the quick release on the handlebar post and adjust by sliding the handlebar mount up or down as desired. Then tighten the quick release to secure the handlebar post. Note the final position mark on the handlebar post for future reference.

#### Adjustment of Handlebar's Forward/Aft Position

3. Loosen the quick release under the handlebar and slide the handlebar forward or backward as desired. A suitable forward/aft position should allow the rider to comfortably grasp the handlebar with a slight bend at the elbow.
4. Tighten the quick release to secure the handlebar assembly.

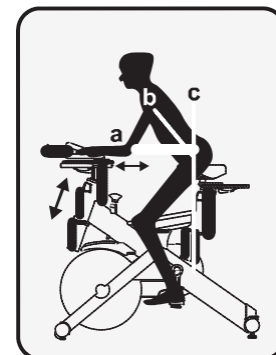

# DUAL FUNCTION PEDAL

## ADJUSTING THE PEDAL STRAPS

Place your feet in between the aluminum surface of the pedal and the nylon foot strap that wraps around it. If the opening is too narrow, depress the spring loaded clasp with one hand and pull on the nylon strap with the other to increase the opening area. If it is too loose or to tighten the strap, depress the spring loaded clasp, then pull on the open end of the nylon strap until the strap is snug around each foot.

## USING THE CLEAT PEDALS

Engage cleated shoes in pedals by placing cleat between bindings while pushing down. Disengage by twisting heel outwards away from exercise bike.

Binding tension is adjustable and should be set so that cleat and shoe do not disengage when pedaling. Use an Allen key to turn tension adjusting screws, clockwise to increase binding tension, counterclockwise to decrease binding tension.

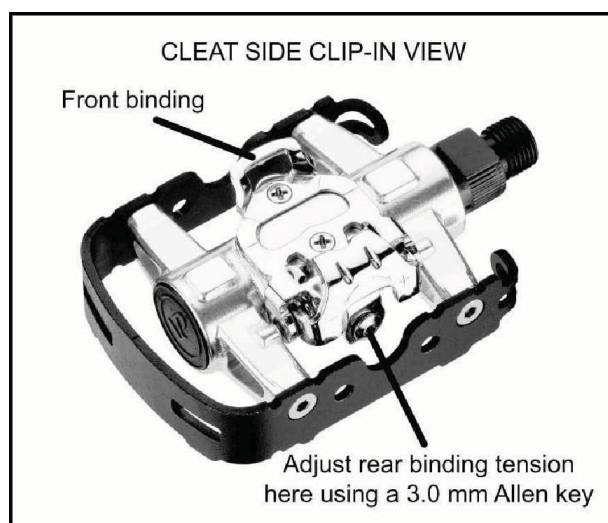
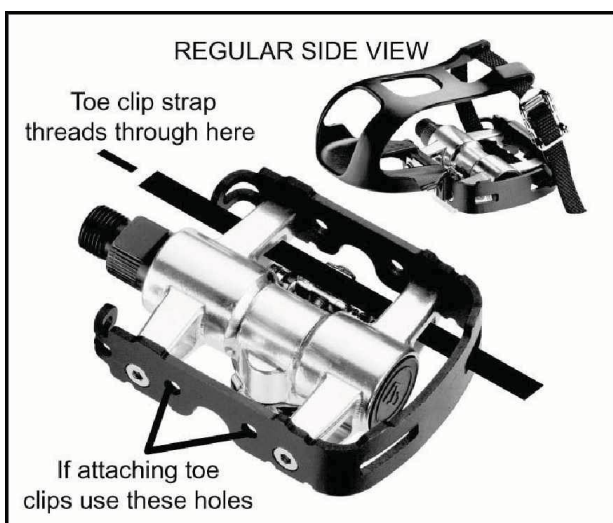

## TROUBLESHOOTING

### No Display on Console

1. Hold down any key to bring the console to “Quick Start” mode.
2. Ensure that the batteries are installed properly in the console and transmitter. If they are, install fresh batteries.

### No Heart Rate signal displayed (chest strap transmitter sold separately)

1. Ensure that your chest strap is worn correctly and that there is moisture under the electrodes.
2. Relocate the bike away from any equipment that could potentially interrupt the radio frequency signal, such as a DVD player or television, etc.

### Cadence number jumps high or low

1. Separate bikes that may be set to the same console code and are cross-talking, or re-synchronize the transmitter and console (see page 7).
2. Relocate the bike to a different part of the room, away from any RF interference areas.

### Heart Rate signal gets interrupted or drops out (chest strap transmitter sold separately)

1. Ensure that there is a minimum distance of 36 inches between bikes.
2. Verify that your chest strap is secure and that the electrodes are making contact with your chest at all times.

### CAUTION!!

EXTERNAL INTERFERENCE MAY BE CAUSED BY OTHER ELECTRONIC DEVICES, SUCH AS: NEARBY TELEVISIONS, STEREO EQUIPMENT, SPEAKERS, ELECTRICAL WIRE CABLING, ETC. IF YOU EXPERIENCE DISTURBANCES IN THE CONSOLE DISPLAY TRY MOVING YOUR BIKE(S) AWAY FROM POTENTIAL RF INTERFERENCE AREAS.

## MAINTENANCE GUIDELINES

### MAINTENANCE SCHEDULE

PART	RECOMMENDED ACTION	FREQUENCY	CLEANER	LUBRICANT
Pedals	Ensure that pedals are tight in crank arms; that all screws on pedals are tight; and that the pedal straps are not frayed	Before each use	N/A	N/A
Frame	Wipe down by using a soft damp clean cloth	Daily	Water	N/A
Flywheel	Wipe down by spraying on a rag and applying a light coat to sides of the flywheel	Weekly	WD-40 spray.	N/A
Brake Pad	Inspect for excessive wear or squealing	Weekly	N/A	Silicone Spray

1. Do not service internal parts of pedals. If they are found to be worn internally, we recommend replacing the pedal.
2. Use of lubricants or cleaning solutions other than those so specified will result in diminished performance and a shorter life span for that part.



## REPLACING SENSOR TRANSMITTER BATTERIES

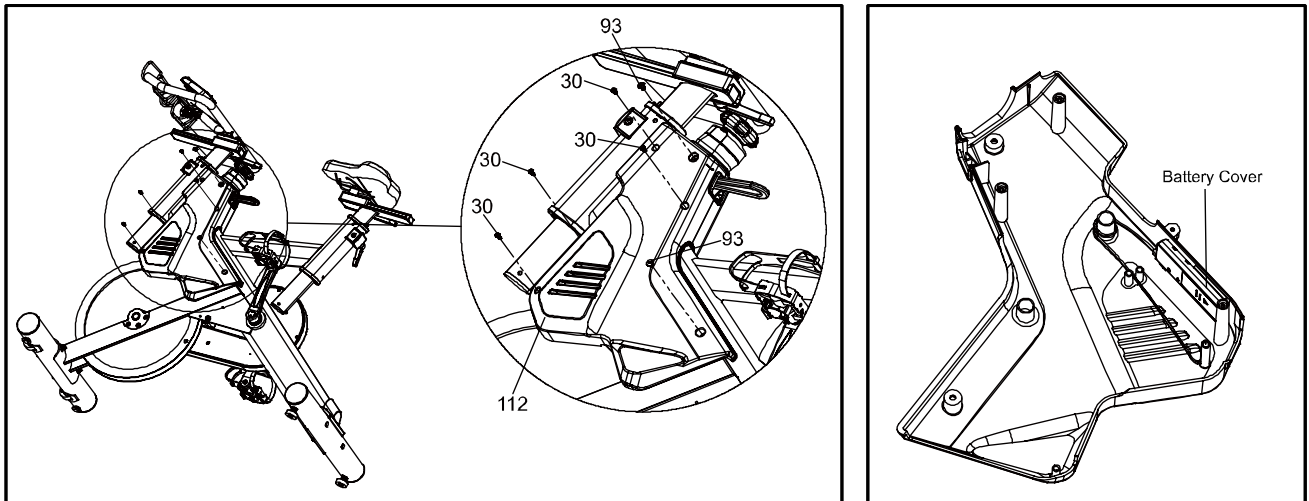

1. Remove the left cover (**112**) by removing four screws (**30**) and two screws (**93**).
2. Without removing the transmitter from the left cover (**112**), remove the Battery Cover from the transmitter.
3. Install 2 AAA batteries in the battery compartment and reinstall the battery cover.
4. When new batteries are installed in the transmitter or console you must perform the synchronizing procedure below for the console to work properly
5. After synchronizing, make sure the wire from transmitter is wrapped around the plastic as in the above image.
6. Reinstall left cover.

### SYNCHRONIZING THE TRANSMITTER TO THE CONSOLE:

After installing the batteries, and before attaching the console and transmitter to the bike, you must synchronize the two so they can 'talk' to each other.

1. Press and hold the two keys on the front of the console for about 3 seconds until the display shows ID - -
2. Now press and hold the blue button on the transmitter for 3 seconds and release. The console display should show ID 0. NOTE: You must press the blue button within 10 seconds after the console is showing ID - - otherwise the console will show: ID ER. If the console shows this error then restart the procedure again.
3. It may be necessary to remove and re-install the batteries in both the console and transmitter if you continue to receive an error.

### REPLACING CONSOLE BATTERIES

When the "Low Battery" indicator shows up on the display it is time to change the batteries.

1. Remove the battery cover from the back of the computer.
2. Insert 2 AAA batteries into the battery compartment and reinstall the battery cover.

# MANUFACTURER'S LIMITED WARRANTY

## INDOOR CYCLE WARRANTY

Effective May 1, 2019

SOLE warrants all its indoor cycles' parts for a period of time listed below from the date of retail sale, as determined by sale receipt, or in the absence of a sales receipt eighteen (18) months from the original factory shipping date. SOLE's responsibilities include providing new or remanufactured parts, at SOLE's option, and technical support to our independent dealers and servicing organizations. In the absence of a dealer or service organization, these warranties will be administered by SOLE directly to a consumer. The warranty period applies to the following components:

<b>RESIDENTIAL WARRANTY</b> (All service is performed In-Home)		<b>LIGHT COMMERCIAL WARRANTY</b> (All service is performed In-Facility)	
Parts/Electronics	3 Years	Parts/Electronics	3 Years
Frame	Lifetime	Frame	Lifetime
Labor	1 Year	Labor	1 Year

## NORMAL RESPONSIBILITIES OF THE CONSUMER

This warranty applies only to products in ordinary household use, and the consumer is responsible for the items listed below:

1. The warranty registration card must be completed and returned to the address listed on the card within 10 days of the original purchase to validate the manufacturer's limited warranty.
2. Proper use of the indoor cycle in accordance with the instructions provided in this manual
3. Proper installation in accordance with instructions provided with the indoor cycle
4. Expenses for making the indoor cycle accessible for servicing, including any item that was not part of the indoor cycle at the time it was shipped from the factory.
5. Damages to the indoor cycle finish during shipping, installation or following installation.
6. Routine maintenance of this unit as specified in this manual.

## EXCLUSIONS

This warranty does not cover the following:

1. CONSEQUENTIAL, COLLATERAL, OR INCIDENTAL DAMAGES SUCH AS PROPERTY DAMAGE AND INCIDENTAL EXPENSES RESULTING FROM ANY BREACH OF THIS WRITTEN OR ANY IMPLIED WARRANTY.  
*Note: Some states do not allow the exclusion or limitation of incidental or consequential damages, so this limitation or exclusion may not apply to you.*
2. Service call reimbursement to the consumer. Service call reimbursement to the dealer that does not involve malfunction or defects in workmanship or material, for units that are beyond the warranty period, for units that are beyond the service call reimbursement period, for indoor cycle not requiring component replacement, or indoor cycle not in ordinary household use.
3. Damages caused by services performed by persons other than authorized SOLE service companies; use of parts other than original SOLE parts; or external causes such as corrosion, discoloration of paint or plastic, alterations, modifications, abuse, misuse, accident, improper maintenance, inadequate power supply, or acts of God.
4. Products with original serial numbers that have been removed or altered.
5. Products that have been: sold, transferred, bartered, or given to a third party.
6. Products that do not have a warranty registration card on file at SOLE. SOLE reserves the right to request proof of purchase if no warranty record exists for the product.
7. THIS WARRANTY IS EXPRESSLY IN LIEU OF ALL OTHER WARRANTIES EXPRESSED OR IMPLIED, INCLUDING THE WARRANTIES OF MERCHANTABILITY AND/OR FITNESS FOR A PARTICULAR PURPOSE.
8. Product use in any environment other than a residential setting.
9. Warranties outside of North America may vary. Please contact your local dealer for details.

## SERVICE

Keep your bill of sale. Twelve (12) months from the date on the bill of sale or eighteen (18) months from the date of factory shipping as determined by the serial number establishes the labor warranty period should service be required. If service is performed, it is in your best interest to obtain and keep all receipts. This written warranty gives you specific legal rights. You may also have other rights that vary from state to state. Service under this warranty must be obtained by following these steps, in order:

1. Contact your selling authorized SOLE dealer. OR
2. Submit all service requests including serial number, contact information and a brief description of the problem online at [www.soleindoorcycles.com/technical.php?p=service](http://www.soleindoorcycles.com/technical.php?p=service).
3. If you have any questions about your new product or questions about the warranty contact SOLE Fitness at 1-866-780-SOLE (7653). If you have a technical problem with your new indoor cycle contact SOLE technical service at 866-MYSOLE1 (697-6531).
4. If no local service is available, SOLE will repair or replace the parts, at SOLE's option, within the warranty period at no charge for parts. All transportation costs, both to our factory and upon return to the owner, are the responsibility of the owner. The owner is responsible for adequate packaging upon return to SOLE. SOLE is not responsible for damages that occur during shipping. Make all freight damage claims with the appropriate freight carrier. DO NOT SHIP ANY UNIT TO OUR FACTORY WITHOUT A RETURN AUTHORIZATION NUMBER. All units arriving without a return authorization number will be refused.
5. For any further information, or to contact our service department by mail, send your correspondence to:

**SOLE Fitness**  
**P.O. Box 2037**  
**Jonesboro, AR 72402-2037**

Product features or specifications as described or illustrated are subject to change without notice. All warranties are made by SOLE.

**Before returning your Sole product to any retailer, or if you require any assistance with assembly or technical support please call us first for assistance at 866-697-6531. Thank you for your Sole purchase.**

**SOLE**<sup>™</sup>  
FITNESS