

fuel

FITNESS



FE44 ELLIPTICAL OWNER'S MANUAL

PLEASE CAREFULLY READ THIS ENTIRE MANUAL BEFORE OPERATING YOUR NEW ELLIPTICAL

TABLE OF CONTENTS

Product Registration	1
Important Safety Instructions	2
Important Electrical Instructions	3
Important Operation Instructions	3
FE44 Assembly Instructions	6
Operation of Your Console	11
General Maintenance	19
Manufacturer's Limited Warranty	20

ATTENTION

THIS ELLIPTICAL IS INTENDED FOR **RESIDENTIAL USE ONLY** AND IS WARRANTED FOR THIS APPLICATION. ANY OTHER APPLICATION **VOIDS** THIS WARRANTY IN ITS ENTIRETY.



Congratulations On Your New Elliptical and Welcome to the FUEL Fitness Family!

Thank you for your purchase of this quality elliptical from **FUEL Fitness**. Your new elliptical has been manufactured by one of the leading fitness manufacturers in the world. **FUEL Fitness** will do all we can to make your ownership experience as pleasant as possible for many years to come. If you have questions, or if parts are missing or damaged, or you require customer service, call 1-866-697-6531. Please have your model number and serial number handy when you call.

Please take a moment to record where you purchased your machine, as well as the date of purchase for future reference. We appreciate your confidence in **FUEL Fitness** and we will always remember that you are the reason that we are in business. Please complete and mail your registration card today and enjoy your new elliptical.

Yours in Health,
FUEL Fitness

Purchase Location

Purchase Date

PRODUCT REGISTRATION

RECORD YOUR SERIAL NUMBER

Please record the Serial Number of this fitness product in the space provided below.

Serial Number

Serial Number Location



REGISTER YOUR PURCHASE

The self-addressed product registration card must be completed in full and returned to **FUEL Fitness**. You can also go to ***www.fuelfitnessusa.com*** to register online.

IMPORTANT SAFETY INSTRUCTIONS

When using an electrical appliance, basic precautions should always be followed, including the following:

Read all instructions before using this appliance.

DANGER - To reduce the risk of electric shock:

1. Always unplug this appliance from the electrical outlet immediately after using and before cleaning.

WARNING - To reduce the risk of burns, fire, electric shock, or injury to persons:

1. An appliance should never be left unattended when plugged in. Unplug from outlet when not in use, and before putting on or taking off parts.
2. Do not operate under blanket or pillow. Excessive heating can occur and cause fire, electric shock, or injury to persons.
3. Close supervision is necessary when this appliance is used by, on, or near children, or disabled persons.
4. Use this appliance only for its intended use as described in this manual. Do not use attachments not recommended by the manufacturer.
5. Never operate this appliance if it has a damaged cord or plug, if it is not working properly, if it has been dropped or damaged, or dropped into water. Return the appliance to a service center for examination and repair.
6. Do not carry this appliance by supply cord or use cord as a handle.
7. Keep the cord away from heated surfaces.
8. Never operate the appliance with the air openings blocked. Keep the air openings free of lint, hair, and the like.
9. Never drop or insert any object into any opening.
10. Do not use outdoors.
11. Do not operate where aerosol (spray) products are being used or where oxygen is being administered.
12. Connect this appliance to a properly grounded outlet only.
13. The appliance is intended for household use.

Fitness Equipment Safety Instructions

- To disconnect, turn all controls to the off position, then remove the plug from the outlet.
- Do not operate equipment on deeply padded, plush or shag carpet. Damage to both carpet and equipment may result. Before beginning this or any exercise program, consult a physician. This is especially important for persons over the age of 35 or persons with pre-existing health conditions.
- Keep hands away from all moving parts.
- The pulse sensors are not medical devices. Various factors, including the user's movement, may affect the accuracy of heart rate readings. The pulse sensors are intended only as exercise aids in determining heart rate trends in general.
- Do not attempt to use your equipment for any purpose other than for the purpose it is intended.
- Wear proper shoes. High heels, dress shoes, sandals or bare feet are not suitable for use on your equipment. Quality athletic shoes are recommended to avoid leg fatigue.

Failure to follow all guidelines may compromise the effectiveness of the exercise experience, expose yourself (and possibly others) to injury, and reduce the longevity of the equipment.

SAVE THESE INSTRUCTIONS - THINK SAFETY!

IMPORTANT ELECTRICAL INSTRUCTIONS

WARNING!

- **NEVER** remove any cover without first disconnecting AC power supply.
- If A.C. voltage varies by ten percent (10%) or more, the performance of your elliptical may be affected. Such conditions are not covered under your warranty. If you suspect the voltage is low, contact your local power company or a licensed electrician for proper testing.
- **NEVER** expose this elliptical to rain or moisture. This product is NOT designed for use outdoors, near a pool or spa, or in any other high humidity environment. Maximum environmental ratings are 40-120 degrees Fahrenheit, 95% humidity non-condensing (no water droplets forming on surfaces).



Plug-In

IMPORTANT OPERATION INSTRUCTIONS

- **NEVER** operate this elliptical without reading and completely understanding the results of any operational change you request from the computer.
- Understand that changes in resistance do not occur immediately. Set your desired level on the computer console and release the adjustment key. The computer will obey the command gradually.
- **NEVER** use your elliptical during an electrical storm. Surges may occur in your household power supply that could damage elliptical components.
- Use caution while participating in other activities while using your elliptical such as watching television, reading, etc. These distractions may cause you to lose balance, resulting in serious injury.
- Always hold on to a handlebar while making control changes.

TRANSPORTATION

The elliptical is equipped with transport wheels, which are engaged when the rear of the elliptical is lifted.

EXITING DISPLAY MODE

This product is preset to a DISPLAY MODE that keeps the console continually powered on. To turn this feature off and allow your display to go into DISPLAY MODE when not being used, please use the following procedure:

1. When in stand-by status, hold **Start**, **Stop** and **Enter** keys for five seconds to enter the Engineering Mode.
2. Use the **▲ / ▼** keys to choose SELECT FUNCTION, then press the **ENTER** key.
3. Use the **▲ / ▼** keys to select the DISPLAY MODE, then press **Enter** key.
4. Use the **▲ / ▼** keys to turn ON or OFF the DISPLAY MODE function.
5. Hold the **Stop** key to save and exit Engineering Mode.

FE44 ASSEMBLY PACK CHECKLIST

HARDWARE STEP 1

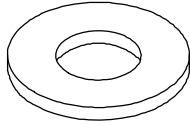

#94. 3/8" Flat Washer (2 pcs)

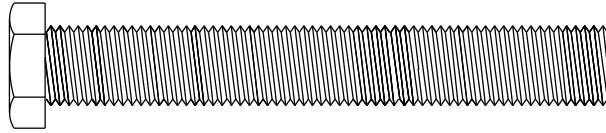

#119. 3/8" x 3" Hex Head Bolt (3 pcs)

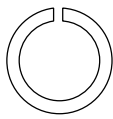

#120. 3/8" Split Washer (4 pcs)

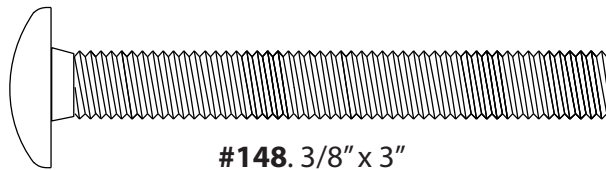

#148. 3/8" x 3" Carriage Bolt (2 pcs)

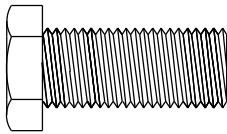

#121. 3/8" x 3/4" Hex Head Bolt (1 pc)

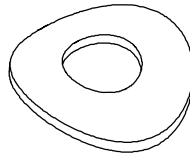

#149. 3/8" Curved Washer (4 pcs)



#150. 3/8" Cap Nut (2 pcs)

HARDWARE STEP 2

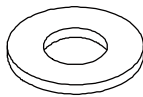

#147. 5/16" Flat Washer (2 pcs)

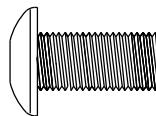

#151. 5/16" Button Head Socket Bolt (2 pcs)

HARDWARE STEP 3

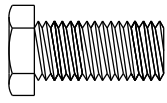

#70. 5/16"
Hex Head Bolt
(6 pcs)

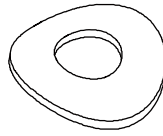

#102. 5/16" Curved
Washer (6 pcs)

HARDWARE STEP 4

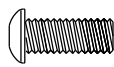

#78. M5 x 10mm
Phillips Head Screw
(4 pcs)



#79. M5 x 15mm
Phillips Head Screw
(8 pcs)

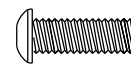

#68-3. M5 x 12mm
Phillips Head Screw (2 pcs)

ASSEMBLY TOOLS

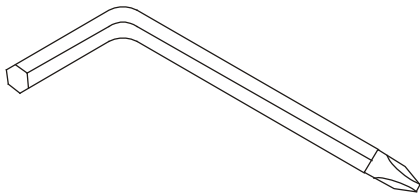

#108. M5 Allen Wrench /
Phillips Head Screw Driver

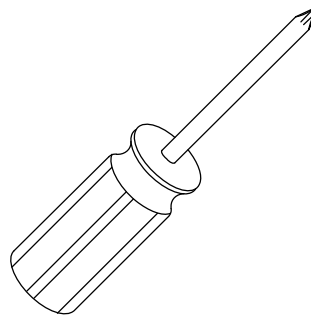

#110. Phillips Head
Screw Driver

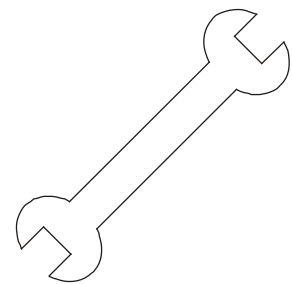

#111. 12.14mm Wrench

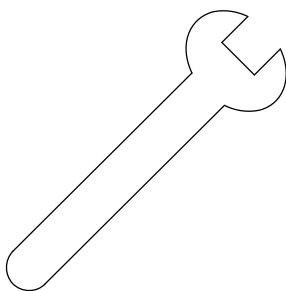

#113. 12mm Wrench

FE44 ASSEMBLY INSTRUCTIONS

1 CONSOLE MAST & CONSOLE

1. Locate the Console Mast (**10**) and Console Mast Cover (**41**) and slide the Cover onto the Mast as far as it will go. Make sure the Console Mast Cover (**41**) is facing the correct way.
2. At the top opening of the Main Frame (**1**) of the elliptical is a Computer Cable (**32**). Unravel and straighten out the Computer Cable (**32**) and feed it into the bottom of the Console Mast tube (**10**) and out of the top opening.
3. Install the Console Mast (**10**) into the receiving bracket in the top of the Main Frame (**1**) Put the two Split Washers (**120**) and two Curved Washers (**149**) onto the one Hex Head Bolt (**119**) and one Hex Head Bolt (**121**) then install the screw at the front of the Console Mast. Put two Flat Washers (**94**) , two Split Washers (**120**) onto the two Hex Head Bolts (**119**). Install tighten by using the 12.14m/m Wrench (**111**).
4. NOTE: There is an electrical wire running through the Console Mast Tube (**10**). Be careful not to damage or pinch this Computer Cable (**32**) during this procedure.
5. Install the Front Stabilizer(**15**) on the front stabilizer holding plate at the bottom of the main frame with the transportation wheels facing forward and secure them with two Carriage Bolts (**148**), two Curved Washers(**149**) and two Cap Nuts (**150**) by using 12.14m/m Wrench(111).

Hardware Step 1

#94. 3/8" Flat Washer (2 pcs)
#119. 3/8" x 3" Hex Head Bolt (3 pcs)
#120. 3/8" Split Washer (4 pcs)
#121. 3/8" x 3/4" Hex Head Bolt (1 pc)
#148. 3/8" x 3" Carriage Bolt (2 pcs)
#149. 3/8" Curved Washer (4 pcs)
#150. 3/8" Cap Nut (2 pcs)

1

CONSOLE MAST & CONSOLE

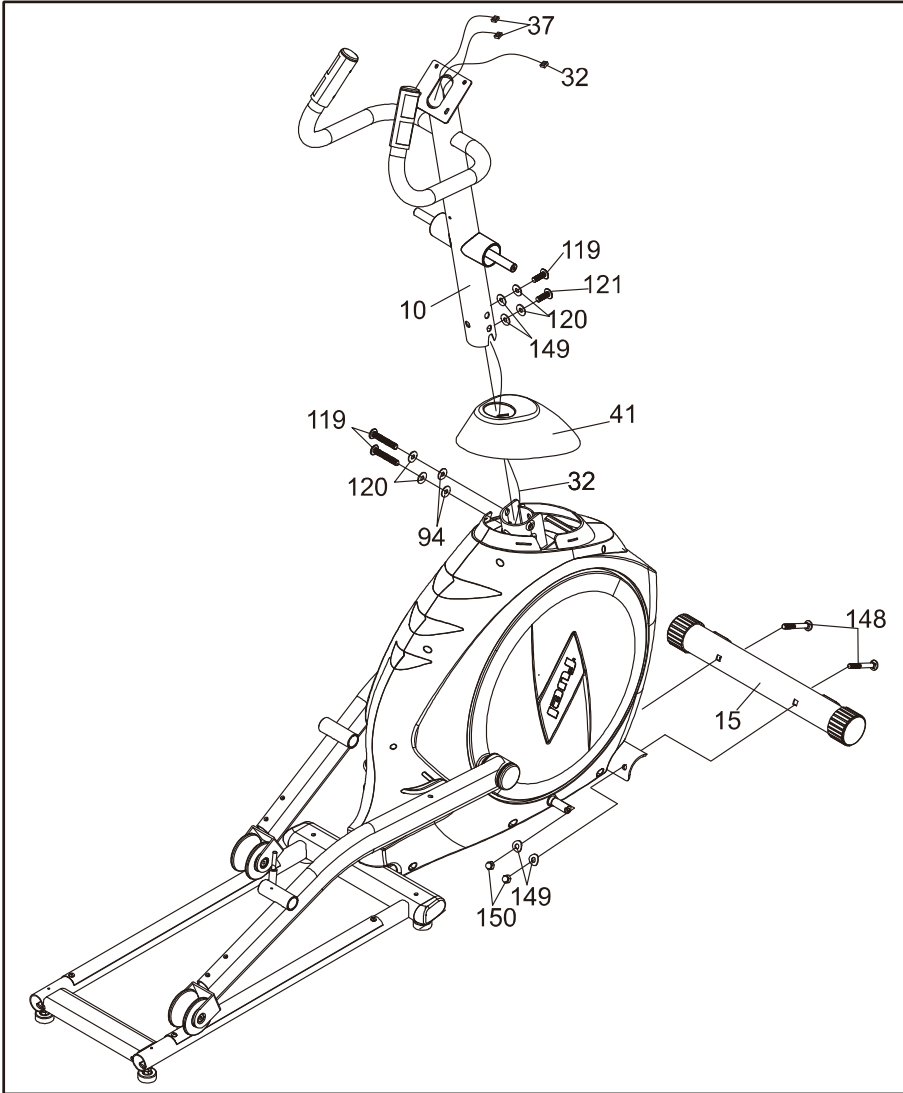

2 SWING ARMS

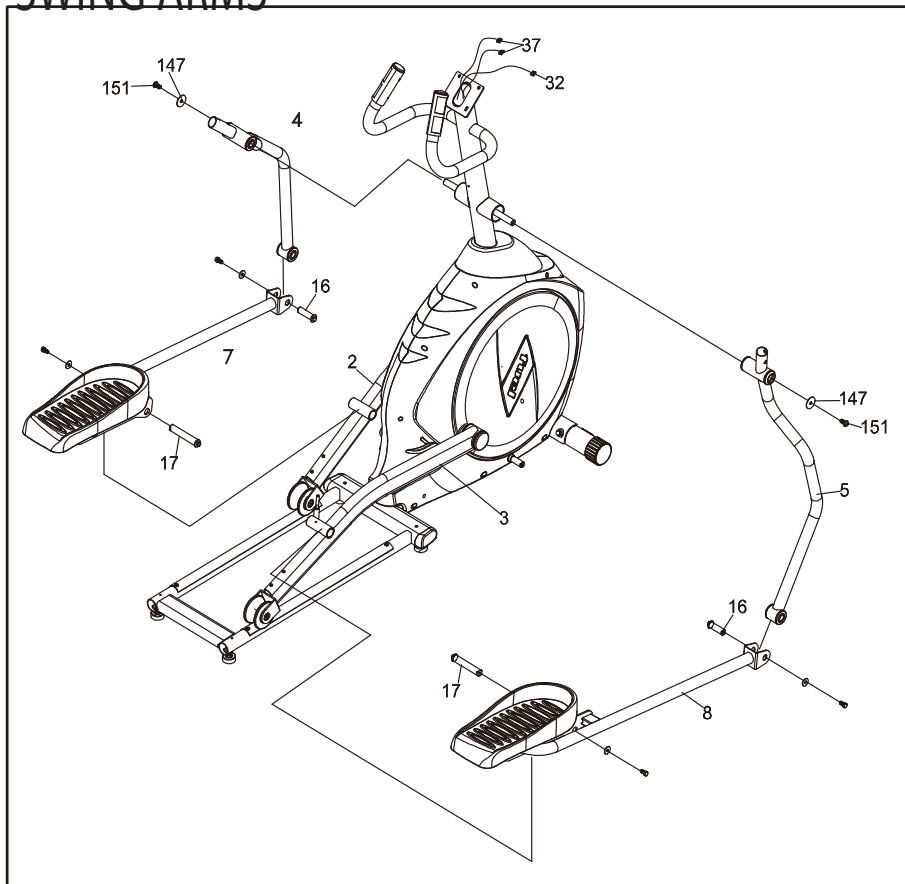

Hardware Step 2

#147. 5/16" Flat Washer (2 pcs)
#151. 5/16" Button Head Socket Bolt (2 pcs)

1. Slide the left and right Lower Swing Arms (**4 & 5**) onto the axle of the Mast and secure with two 5/16" Button Head Socket Bolts (**151**) and two Flat Washers (**147**) by using Combination M5 Allen Wrench & Phillips Head Screw Driver (**108**).
2. Remove the Pedal Axle (**17**) from left Pedal Arm (**2**) and install left Connecting Arm (**7**) onto left Pedal Arm. Reinstall the Axle and the screw and tighten with 12mm and 14mm open end wrench. Repeat the same procedure again for the right Connecting Arm (**8**) and Pedal Arm (**3**).
3. Remove the axles (**16**) which are on left and right connecting arms (**7 & 8**). Connect the left and right connecting arm (**7 & 8**) with left and right lower handle bar (**4 & 5**) and reinstall the axles (**16**) and the screw and tighten with the Wrench (**111**).

3

CONNECTING ARMS & REAR RAILS

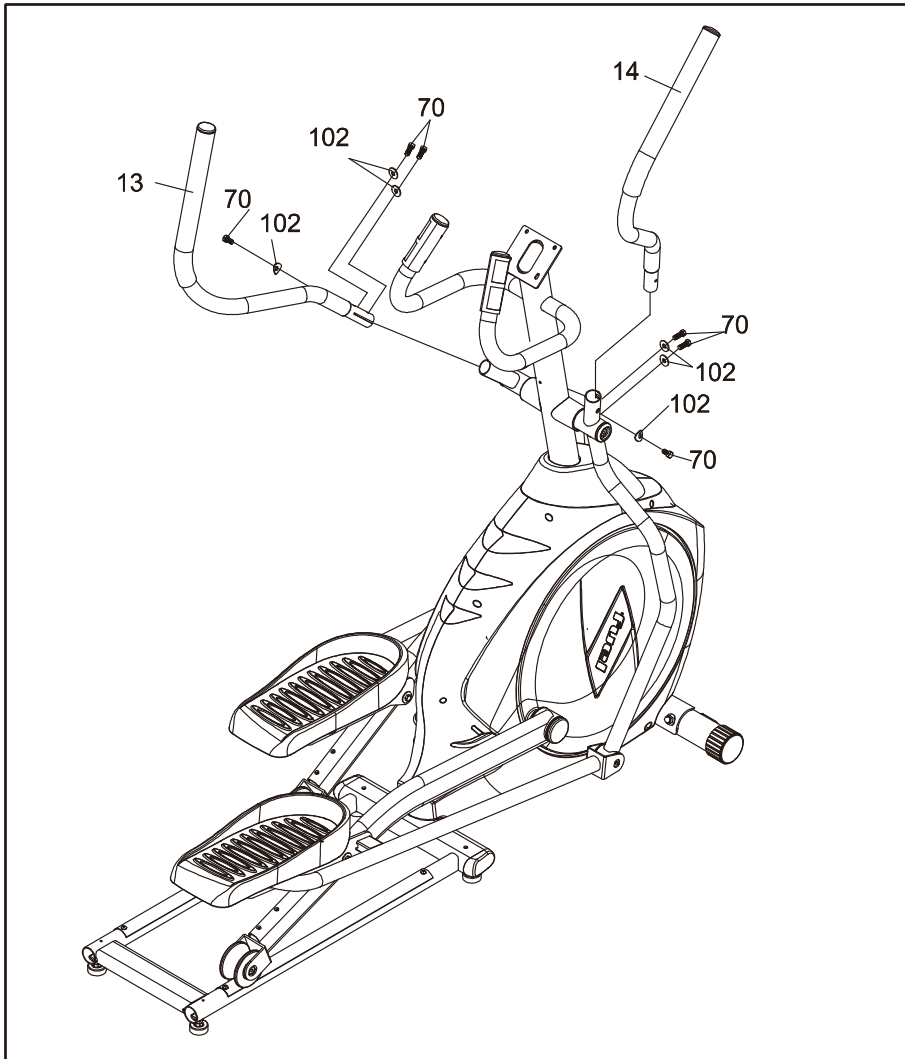

Hardware Step 3

#70. 5/16" Hex Head Bolt
(6 pcs)

#102. 5/16" Curved
Washer (6 pcs)

1. Install the Left and Right Swing Arms (**13 & 14**) into the Lower Left and Right Lower Handle Bars (**4 & 5**) with six Hex Head Bolts (**70**) and six Curved Washers (**102**) by using the 12.14m/m_Wrench (**111**).

4 PLASTIC COVERS

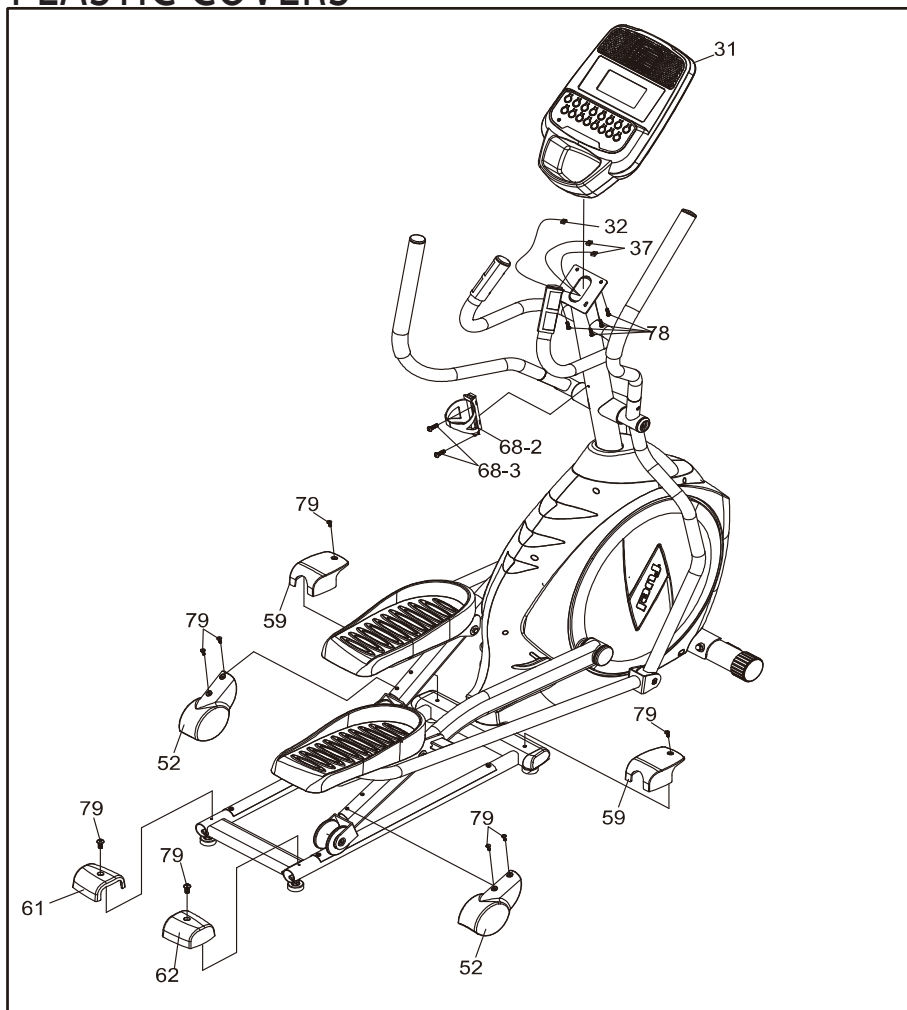

Hardware Step 4

#78. M5 x 10mm
Phillips Head Screw
(4 pcs)

#79. M5 x 15mm
Phillips Head Screw
(8 pcs)

#68-3. M5 x 12mm
Phillips Head Screw (2 pcs)

Note: Use the M5 Allen Wrench/Phillips Head Screw Driver (108) to tighten hardware in this step.

1. Locate the Console Assembly (31) and the four Phillips Head Screws (78). There will be two electrical wire connectors at the top opening of the Console Mast (10), two Hand pulse wires (37), one Computer Cable (32). Connect these to the mating connectors on the back of the Console Assembly (31). The connectors are keyed so you cannot plug them in the wrong way so do not force them.
3. Storing the excess wire back into the Console Mast (10), carefully install the Console Assembly (31) onto the mounting plate of Console Mast (10) and secure using the four Phillips Head Screws (78)
4. Install the two pcs of Slide Wheel Covers (52) and the four Phillips Head Screws (79) by using the Phillips Head Screw Driver (110).
5. Use one Phillips Head Screw (79) to secure Rear Stabilizer Cover (L) (61) on the Pedal Arm (L) and Rail Tube with Phillips Head Screw Driver (110). Repeat the procedure for Rear Stabilizer Cover (R) (62) for the other side.
6. Use two Phillips Head Screw (79) to secure Middle Stabilizer Cover (59) on the Pedal Arm (L,R) and Rail Tube with Phillips Head Screw Driver (110).
7. Use Phillips head screw driver to tighten Drink Bottle Holder on Console Mast tube with two M5 x 12m/m_Phillips Head Screws (68-3).

OPERATION OF YOUR ELLIPTICAL

FE44 Console



POWER UP

Power the elliptical on by plugging it into an appropriate wall outlet.

When it is first powered on, the console will perform an internal self-test. During this time all the lights will turn on, the Message Window display will show a software version (i.e.: VER 1.0), and the Distance Window will display an odometer reading. The odometer shows how many virtual miles the elliptical has gone. The Time Window shows how many total hours the elliptical has been used.

The odometer and time will remain displayed for only a few seconds then the console will go to the startup display. The dot matrix display will be scrolling through the different workout profiles and the Message Window will be scrolling the start up message. You may now begin to use the console.

CONSOLE OPERATION

QUICK START MODE

This is the quickest way to start a workout. After the console powers up you just press the Start key to begin, this will initiate the Quick Start mode. In Quick Start, the time will count up from zero. The resistance level can be adjusted manually by pressing the Level UP/DOWN buttons.

Basic Information and Functions:

Message Window:

Each time the Enter button is pressed the next set of information will appear. In Data Scan mode, the displayed information will change every 4 seconds in the Message Window. The Message Window will initially display Segment Time then Total Laps, Level and Data Scan.

The Stop button actually has several functions. Pressing the Stop key once during a program will Pause the program for 5 minutes. If you need to get a drink, answer the phone or any of the many things that could interrupt your workout, this is a great feature. To resume your workout during Pause just press the Start key. If the Stop button is pressed twice during a workout the program will end and a Workout Summary is displayed.

If the Stop key is held down for 3 seconds the console will perform a complete Reset. During data entry for a program the Stop key performs a Previous Screen function. This allows you to go back one step in the programming each time you press the Stop key.

There is an Audio In Jack (🎵) on the front of the console and built-in speakers. You may plug any low-level audio source signal into this port. Audio sources include MP3, iPod, portable radio, CD player or even a TV or computer audio signal.

A message about Calories: Calorie readings on every piece of exercise equipment, whether it is in a gym or at home, are not accurate and tend to vary widely. They are meant only as a guide to monitor your progress from workout to workout. The only way to measure your calorie burn accurately as in a clinical setting connected to a host of machines. This is because every person is different and burns calories at a different rate.

ENTERING A PROGRAM/CHANGING SETTINGS

The profile for each program will be displayed in the dot matrix window. Press the Program key to select a program and begin customizing the settings. If you want to workout without entering new settings, then just press the Start key. This will bypass the programming of data and take you directly to the start of your workout. If you want to change the personal settings, then just follow the instructions in the Message Window. If you start a program without changing the settings, the default settings will be used.

Note: Age and Weight default settings will change when you enter a new number. So the last Age and Weight entered will be saved as the new default settings. If you enter Age and Weight the first time use the elliptical you will not have to enter it every time you work out unless either Age or Weight has changed or someone else enters a different Age and Weight.

MAINTENANCE MENU IN CONSOLE SOFTWARE

The console has built in maintenance/diagnostic software. The software will allow you to change the console settings from English to Metric and turn off the beeping of the speaker when a key is pressed for example. To enter the Maintenance Menu (may be called Engineering Mode, depending on version) press and hold down the Start, Stop and Enter keys keep holding the keys down for about 5 seconds and the Message Window will display "Engineering Mode". Press the Enter button to access the menu below. Press the Level UP/DOWN keys to navigate the menu.

- A. Key Test - Will allow you to test all the keys to make sure they are functioning
- B. Display Test - Automatically tests all LCD's
- C. Functions - Press Enter to access settings, use Level UP/DOWN keys to scroll
 - I. ODO Reset - Resets the odometer
 - II. Units - Choose from English(Imperial) or Metric display readings
 - III. Display Mode - Turn off to have the console power down automatically after 30 minutes of inactivity
 - IV. Motor Test - Continually runs the tensioning gear motor
 - V. Manual - Allows stepping of the gear motor
 - VI. Pause Mode - Turn on to allow 5 minutes of pause, turn off to have console pause indefinitely
 - VII. Key Tone -Turn on or off the beep sound when a key is pressed
- D. Security - Allows you to lock the keypad so no unauthorized use of the machine is allowed. When the child lock is enabled, the console will not allow the keypad to operate unless you press and hold the Start and Enter buttons for 3 seconds to unlock the console.
- E. Factory Set
- F. Exit - Select to exit Maintenance Menu

PROGRAMMABLE FEATURES

MANUAL PROGRAM

The Manual program works as the name implies, manually. This means that you control the workload yourself and not the computer.

1. Press Manual key then press the Enter key.
2. The Message Window will ask you to enter your Age. You may adjust the age setting using the Level UP/DOWN keys, then press the Enter key to accept the new number and proceed on to the next screen.
3. You are now asked to enter your Weight. You may adjust your weight setting using the Level UP/DOWN keys, then press Enter to continue.
4. Next is the Time. You may adjust the length of Time by pressing the keys, then press Enter to continue.
5. Now you are finished editing the settings and can begin your workout by pressing the Start key. You can also go back and modify your settings by pressing the Stop key to go back one level of the programming screen.
6. Once the program starts the elliptical will be set to level one. This is the easiest level and it is a good idea to stay at level one for a while to warm up. If you want to increase the work load at any time press the Level UP key; the Level DOWN key will decrease the workload.
7. During the Manual program you will be able to scroll through the data in the Message Window by pressing the Enter key.
8. When the program ends the Message Window will show a summary of your workout. The summary will be displayed for a short time then the console will return to the startup display.

PROGRAMMING PRESET PROGRAMS

1. Press Program key then press the Enter key.
2. The Message Window will ask you to enter your Age. You may adjust the age setting, using the Level UP/DOWN keys, then press the Enter key to accept the new number and proceed on to the next screen.
3. You are now asked to enter your Weight. You may adjust the weight number using the Level UP/DOWN keys then press Enter to continue.
4. Next is Time. You may adjust the Time and press Enter to continue.
5. Now you are asked to adjust the Max Level. This is the peak exertion level you will experience during the program (the highest colored segment/box of the program profile). Adjust the level and then press Enter.
6. Now you are finished editing the settings and can begin your workout by pressing the Start key. You can also go back and modify your settings by pressing the Stop key to go back one level, or screen.
7. If you want to increase or decrease the resistance at any time during the program press the Level UP / DOWN keys.
8. During the program you will be able to scroll through the data in the Message Window by pressing the Enter key.
9. When the program ends the Message Window will show a summary of your workout. The summary will be displayed for a short time then the console will return to the start-up display.

PRESET PROGRAMS

The console has five different programs that have been designed for a variety of workouts. These five programs have factory preset work level profiles for achieving different goals.

Hill

The Hill program simulates going up and down a hill. The resistance in the pedals will steadily increase and then decrease during the program.

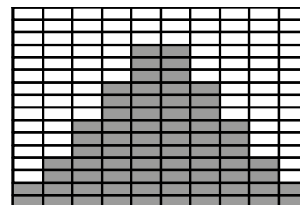

Fat Burn

The Fat Burn program is designed, as the name implies, to maximize the burning of fat. There are many schools of thought on the best way to burn fat but most experts agree that a lower exertion level that stays at a steady workload is the best. The absolute best way to burn fat is to keep your heart rate at around 60% to 70% of its maximum potential. This program does not use heart rate but simulates a lower, steady exertion workout.

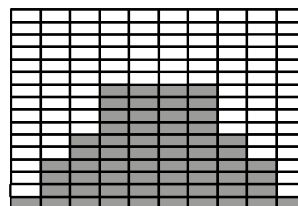

Cardio

The Cardio program is designed to increase your cardiovascular function and endurance. This is exercise for your heart and lungs. It will build up your heart muscle and increase blood flow and lung capacity. This is achieved by incorporating a higher level of exertion with slight fluctuations in work

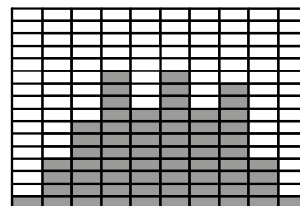

Strength

The Strength program is designed to increase muscular strength in your lower body. This program will steadily increase in resistance to a high level and forces you to sustain it. This is designed to strengthen and tone your legs and glutes (muscles of the butt).

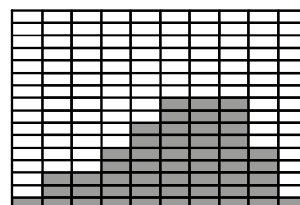

Interval

The Interval program takes you through high levels of intensity followed by periods of low intensity. This program increases your endurance by depleting your oxygen level followed by periods of recovery to replenish oxygen. Your cardiovascular system gets programmed to use oxygen more efficiently this way. This program also forces your body to become more efficient due to spikes in heart rate, between recovery periods. This aids in heart rate recovery from intense activities.

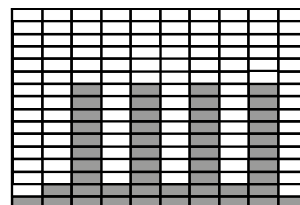

USER PROGRAMS

The customizable User programs allow you to build and save your own workout. You can build your own custom program by following the instructions below.

1. Select the User program (U1 or U2) by USER1 or USER2 program keys then press Enter. If you have already saved a program to either U1 or U2, it will be displayed and you are ready to begin. If not, you will have the option of inputting a username. In the Message Window, the letter "A" will be blinking. Use the Level UP/DOWN buttons to select the appropriate first letter of your name (Pressing the Level button will switch to the letter "B"; pressing the Down button will switch to letter "Z"). Press Enter when the desired letter is displayed. Repeat this process until all of the characters of your name have been programmed (maximum 7 characters). When finished press Stop.
2. If there is a program already stored in User when you press the key, you will have an option to run the program as it is or delete the program and build a new one. At the welcome message screen, when pressing Start or Enter you will be prompted: Run Program? Use the Level UP/DOWN to select Yes or No. If you select No, you will then be asked if you want to delete the currently saved program. It is necessary to delete the current program if you want to build a new one.
3. The Message Window will ask you to enter your Age. You may enter your age using the Level UP/DOWN keys, then press the Enter key to accept the new number and proceed on to the next screen.
4. You are now asked to enter your Weight. You may adjust the weight number using the Level UP/DOWN keys, then press Enter to continue.
5. Next is Time. You may adjust the Time using the Level UP/DOWN keys and press Enter to continue. Now the first column will be blinking and you are asked to adjust the level for the first segment of the
6. Workout. When you finish adjusting the first segment, or if you don't want to change, then press Enter to continue to the next segment. The next segment will show the same level as the previously adjusted segment. Repeat the same process as the last segment then press Enter. Continue this process until all ten segments have been set.
7. The Message Window will then tell you to start to begin (and save the program) or Enter to modify the program. Pressing Stop go back one level.
8. If you want to increase or decrease the workload at any time during the program press the Level UP/DOWN key
9. During the User 1 or User 2 program you will be able to scroll through the data in the Message Window by pressing the Enter key.
10. When the program ends the Message Window will show a summary of your workout. The summary will be displayed for a short time then the console will return to the start-up display.

HEART RATE

The old motto, "no pain, no gain", is a myth that has been overpowered by the benefits of exercising comfortably. A great deal of this success has been promoted by the use of heart rate monitors. With the proper use of a heart rate monitor, many people find that their usual choice of exercise intensity was either too high or too low and exercise is much more enjoyable by maintaining their heart rate in the desired benefit range.

To determine the benefit range in which you wish to train, you must first determine your predicted Maximum Heart Rate. This can be accomplished by using the following formula: 220 minus your age. This will give you the predicted Maximum Heart Rate (MHR) for someone of your age. To determine the effective heart rate range for specific goals you simply calculate a percentage of your MHR. Your heart rate training zone is 50% to 90% of your maximum heart rate. 60% of your MHR is the zone that burns fat, while 80% is for strengthening the cardio vascular system. This 60% to 80% is the zone to stay in for maximum benefit.

For someone who is 40 years old their predicted target heart rate zone is calculated:

$$220 - 40 = 180 \text{ (maximum heart rate)}$$

$$180 \times .6 = 108 \text{ beats per minute} \\ \text{(60\% of maximum)}$$

$$180 \times .8 = 144 \text{ beats per minute} \\ \text{(80\% of maximum)}$$

So for a 40 year old the training zone would be 108 to 144 beats per minute.

The two most popular reasons for, or goals, of exercise are cardiovascular fitness (training for the heart and lungs) and weight control. The black columns on the chart above represent the MHR for a person whose age is listed at the bottom of each column. The training heart rate, for either cardiovascular fitness or weight loss, is represented by two different lines that cut diagonally through the chart. A definition of the lines' goal is in the bottom left-hand corner of the chart. If your goal is cardiovascular fitness or if it is weight loss, it can be achieved by training at 80% or 60%, respectively, of your MHR on a schedule approved by your physician. Consult your physician before participating in any exercise program.

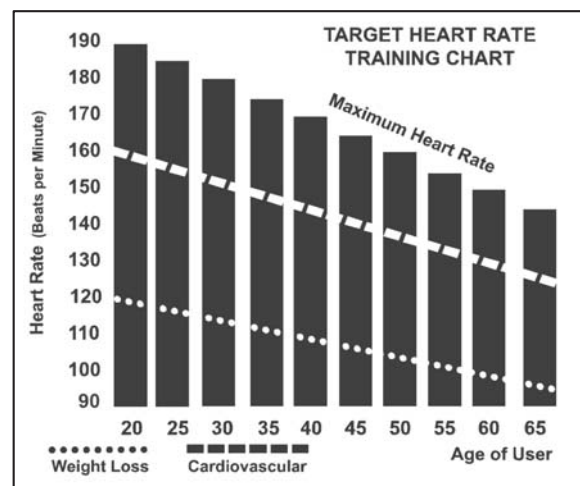

RATE OF PERCEIVED EXERTION

Heart rate is important but listening to your body also has a lot of advantages. There are more variables involved in how hard you should workout than just heart rate. Your stress level, physical health, emotional health, temperature, humidity, the time of day, the last time you ate and what you ate all contribute to the intensity at which you should workout. If you listen to your body it will tell you all of these things.

The rate of perceived exertion (RPE), also known as the Borg scale, was developed by Swedish physiologist G.A.V. Borg. This scale rates exercise intensity from 6 to 20 depending upon how you feel or the perception of your effort.

The scale is as follows:

Rating Perception of Effort

- 6 Minimal
- 7 Very,very light
- 8 Very,very light +
- 9 Very light
- 10 Very light +
- 11 Fairly light
- 12 Comfortable
- 13 Somewhat hard
- 14 Somewhat hard +
- 15 Hard
- 16 Hard +
- 17 Very hard
- 18 Very hard +
- 19 Very,very hard
- 20 Maximal

You can get an approximate heart rate level for each rating by simply adding a zero to each rating. For example a rating of 12 will result in an approximate heart rate of 120 beats per minute. Your RPE will vary depending on the factors discussed earlier. If your body is strong and rested, you will feel strong and your pace will feel comfortable. When your body is in this condition, you are able to train harder and the RPE will support this. If you are feeling tired and sluggish, it is because your body needs a break. In this condition, your pace will feel difficult. Again, this will show up in your RPE and you will train at the proper level for that day.

General Maintenance

1. Wipe down all areas in the sweat path with a damp cloth after each workout.
2. If a squeak, thump, clicking or rough feeling develops, the main cause is most likely one of two reasons:
 - i. The hardware was not sufficiently tightened during assembly. All bolts that were installed during assembly need to be tightened as much as possible. It may be necessary to use a larger wrench than the one provided if you cannot tighten the bolts sufficiently. The majority of calls to the service department for noise issues can be traced to loose hardware or the rear rails being dirty.
 - ii. Dirt build-up on the rear rails and polyurethane wheels are also a source of noise. Noise from build-up on the rails can cause a thumping sound that you would swear is coming from inside the main body of the machine because noise travels and is amplified in the tubing of the frame. Clean the rails and wheels with a lint free cloth and rubbing alcohol. Stubborn build-up can be removed with your thumbnail or a non-metallic scraper, like the back edge of a plastic knife. After cleaning, apply a small amount of lubricant on the rails with your fingers or a lint free cloth. You only need a thin coat of lubrication, wipe off any excess.
3. If squeaks or other noises persist, check that the unit is properly leveled before calling the service department.

ELLIPTICAL NOISES

Your new elliptical is engineered and manufactured to the strictest industry standards and tolerances. All elliptical trainers, no matter who the manufacturer, have a multitude of moving linkages and parts. Be aware that even with the tightest mechanical tolerances there still could be a slight amount of play between some parts. This inherent play can result in slight noises during use such as clicks and small thumps. Please expect that the elliptical will not be completely silent.

ENGINEERING MODE

The console has built in maintenance/diagnostic software. The software will allow you to make changes to the console settings such as changing units from English to Metric or turning off the console beeps (if they are waking your family during your early morning workouts). To enter the Engineering Mode press and hold down the **Start**, **Stop** and **Enter** keys. Keep holding the keys down for about five seconds and the message window will display "Engineering Mode". Press the **Enter** key to access the menu below. Press the **Level Up/Down** keys to navigate the menu.

- A. Key Test - Will allow you to test all the keys to make sure they are functioning
- B. Display Test - Automatically tests all LCD's
- C. Functions - Press Enter to access settings, use Level UP/DOWN keys to scroll
 - i. ODO Reset - Resets the odometer
 - ii. Units - Choose from English(Imperial) or Metric display readings
 - iii. Display Mode - Turn off to have the console power down automatically after 30 minutes of inactivity
 - iv. Motor Test - Continually runs the tensioning gear motor
 - v. Manual - Allows stepping of the gear motor
 - vi. Pause Mode - Turn on to allow 5 minutes of pause, turn off to have console pause indefinitely
 - vii. Key Tone - Turn on or off the beep sound when a key is pressed
- D. Security - Allows you to lock the keypad so no unauthorized use of the machine is allowed. When the child lock is enabled, the console will not allow the keypad to operate unless you press and hold the Start and Enter buttons for 3 seconds to unlock the console
- E. Factory Set
- F. Exit - Select to exit Maintenance Menu

Manufacturer's Limited Warranty

Effective August 1, 2015 -ELLIPTICAL LIMITED WARRANTY

FUEL Fitness Inc. warrants all its home use elliptical parts for a period of time listed below, from the date of retail sale, as determined by a sales receipt or in the absence of a sales receipt, eighteen (18) months from the original factory shipping date. FUEL Fitness' responsibilities include providing new or remanufactured parts, at FUEL Fitness' option, and technical support to our independent dealers and servicing organizations. In the absence of a dealer or service organization, these warranties will be administered by FUEL Fitness directly to a consumer. The warranty period applies to the following components:

Home Use Limited Warranty

Frame & Brake	Parts	Labor
1 Year	1 Year	1 Year

NORMAL RESPONSIBILITIES OF THE CONSUMER

This warranty applies only to products in ordinary household use. The consumer is responsible for the items listed below:

1. The warranty registration card must be completed and returned to the address listed on the card within 10 days of the original purchase to validate the manufacturer's limited warranty or register online at the FUEL Fitness website.
2. Proper use of the elliptical in accordance with the instructions provided in this manual, including maintenance.
3. Proper connection to a power supply of sufficient voltage, replacement of blown fuses, repair of loose connections or defects in house/facility wiring.
4. Expenses for making the elliptical accessible for servicing, including any item that was not part of the elliptical at the time it was shipped from the factory.
5. Damages to the elliptical finish during shipping, installation or following installation.

EXCLUSIONS

This warranty does not cover the following:

1. CONSEQUENTIAL, COLLATERAL, OR INCIDENTAL DAMAGES SUCH AS PROPERTY DAMAGE AND INCIDENTAL EXPENSES RESULTING FROM ANY BREACH OF THIS WRITTEN OR ANY IMPLIED WARRANTY. Note: Some states do not allow the exclusion or limitation of incidental or consequential damages, so this limitation or exclusion may not apply to you.
2. Service call reimbursement to the consumer. Service call reimbursement to the dealer that does not involve malfunction or defects in workmanship or material, for units that are beyond the warranty period, for units that are beyond the service call reimbursement period, for ellipticals not requiring component replacement, or ellipticals not in ordinary household use.
3. Damages caused by services performed by persons other than authorized FUEL Fitness service companies, use of parts other than original FUEL Fitness parts, or external causes such as alterations, modifications, abuse, misuse, accident, improper maintenance, inadequate power supply, or acts of God.
4. Products with original serial numbers that have been removed or altered.
5. Products that have been sold, transferred, bartered, or given to a third party.
6. Products that are used as store display models.
7. Products that do not have a warranty registration on file at FUEL Fitness Inc. FUEL Fitness reserves the right to request proof of purchase if no warranty record exists for the product.
8. Product use in any environment other than a residential setting.
9. THIS WARRANTY IS EXPRESSLY IN LIEU OF ALL OTHER WARRANTIES EXPRESSED OR IMPLIED, INCLUDING THE WARRANTIES OF MERCHANTABILITY AND/OR FITNESS FOR A PARTICULAR PURPOSE.

SERVICE

Keep your bill of sale. Twelve (12) months from the date on the bill of sale or eighteen (18) months from the date of factory shipping as determined by the serial number establishes the warranty period should service be required. If service is performed, it is in your best interest to obtain and keep all receipts. This written warranty gives you specific legal rights. You may also have other rights that vary from state to state. Service under this warranty must be obtained by following these steps, in order:

1. Contact your selling authorized FUEL Fitness dealer. OR
2. Contact your local authorized FUEL Fitness service organization.
3. If there is a question as to where to obtain service, contact our service department at (866)697-6531.
4. FUEL Fitness' obligation under this warranty is limited to repairing or replacing, at FUEL Fitness' option, the product through one of our authorized service centers. All repairs must be preauthorized by FUEL Fitness. If the product is shipped to a service center freight charges to and from the service center will be the customer's responsibility. For replacement parts shipped while the product is under warranty, the customer will be responsible for shipping and handling charges. For in-home service, the customer will be responsible for a trip charge. There will be an additional trip charge if the customer is located over 100 miles from the nearest service center.
5. The owner is responsible for adequate packaging upon return to FUEL Fitness. FUEL Fitness is not responsible for damages in shipping. Make all freight damage claims with the appropriate freight carrier. DO NOT SHIP ANY UNIT TO OUR FACTORY WITHOUT A RETURN AUTHORIZATION NUMBER. All units arriving without a return authorization number will be refused.
6. For any further information, or to contact our service department by mail, send your correspondence to:

FUEL Fitness, Inc.
P.O. Box 2037
Jonesboro, AR 72402-2037

Product features or specifications as described or illustrated are subject to change without notice. All warranties are made by FUEL Fitness, Inc. This warranty applies only in the 48 contiguous United States. NOTE: This does not include Alaska or Hawaii.

